



Data Logger Specification

2022-07-03

Contents

Changelog	2
1 Data Logger	3
2 Connectors	4
3 LED'S	5
4 Mechanical Drawings	5
5 Accessing the Data Logger	5



Changelog

Section	Version	Change
	V0.1	Preliminary Datasheet
	V0.2	Fix voltage range and fix TS+ connector number
	V0.3	Update mechanical drawings and change HV+ connector due to in-availability
	V0.4	Update LED descriptions. Clarify the teams need to provide the vehicle side of the connectors.



1 Data Logger

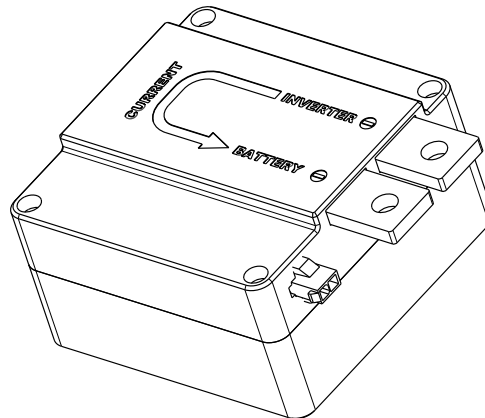

Figure 1: Data Logger (DL) overview

A DL according to this specification will be used and provided by the officials as official measuring system according to EV4.6 and T14.3.

The DL must be mounted according to EV4.6. It must be properly fastened and mounted at a location where it is protected from water.

Its housing has outer dimensions of 100 mm x 100 mm x 59 mm and it weighs approximately 800 g.

CAD-data of the DL can be found on the competition website¹.

The DL must be supplied by a voltage of 12 VDC to 60 VDC. It draws a maximum power of 10 W. It must be reasonably fused in the supply wiring.

The CAN bus interface operates on a data rate of 1 Mbit/s and is not terminated internally.

The CAN message layout can be obtained from a dbc-file provided on the competition website¹.

The Ethernet interface is according to the 100BASE-TX standard and requires a cable at least adhering to ISO/IEC 11801 Cat 5 with an RJ-45 connector. It must be easily accessible for data download. It is recommended to use a RJ45 - M12 d-code cable².

The sensor used by the DL is an Isabellenhütte IVT-500-U3-TOI-CAN2-12³.

The DL must be mounted via 3M™ Dual Lock™.

The pinout of the connectors has to be according to Tables 2 and 3.

¹<https://formulastudent.de/rules>

²https://b2b.harting.com/ebusiness/en_us/RJ45-M12-d-code-str-AWG22-7-PUR-3-0m/09486896018030

³<https://isabellenhuetten.de/en/precision-measurement/standard-products/ivt-series>



2 Connectors

Busbar with 8.1 mm hole(DL-side)

- TS- in current path
- Must be connected fulfilling EV 4.6.4

Molex 0039012026 (DL-side)

- TS+ voltage measurement
- Must be connected fulfilling EV 4.6.5
- Molex 0039012025 (vehicle-side)

Harting 21 03 321 3401 (DL-side)

- Power and CAN interface
- Must power the DL according to EV 4.6.6.
- Can be connected to a vehicle CAN bus to obtain status messages.
- Teams are advised to check the status messages, as they provide the status of the data logger.
- Missing data due to not checking the status messages will be treated as a fault of the team.
- Status messages are sent with a frequency of 50 Hz.
- Status messages contain maximum values (Voltage, Current, Power) of the respective time interval.
- Status messages are provided as a general reference only, only the data stored on the DL will be used for scoring.
- [DV ONLY] CAN Interfaces must be connected to the bus shared with the Remote Emergency System (RES).
- Harting 21 03 319 2401 (vehicle-side)

Pin	Description
1	LV+
2	LV- (GND)
3	CANH
4	CANL

Table 2: DL side Power & CAN Connector (Harting 21 03 321 3401)

Harting 21 03 381 4440 (DL-side)

- 100 Mbit/s Ethernet interface used for connecting to the DL
- A cable must be provided long enough to reach a Data Logger Download Station (DLDS) that is 2 m away from the vehicle.
- A standard Ethernet RJ45 Plug must be provided for the the download station.
- Recommended cable: Harting 09 48 689 6018 030

Pin	Description
1	TX+
2	RX+
3	TX-
4	RX-

Table 3: DL side Ethernet connector (Harting 21 03 381 4440)



The teams must provide the vehicle side of the connectors and all required cables.

3 LED'S

The Datalogger has two LED's, a left one and a right one. During power-up both LED's light up for a short time.

If the system is ready the left LED is always in heartbeat mode.

Status	LED left	LED right
Idle, not logging	heartbeat	green
Logging	heartbeat	orange
Error	off	don't care

Table 4: DL status LEDs

4 Mechanical Drawings

The dimension can be seen in Figure 2.

5 Accessing the Data Logger

Teams can access the data which was recorded on a website that will be announced in a later revision of this document.

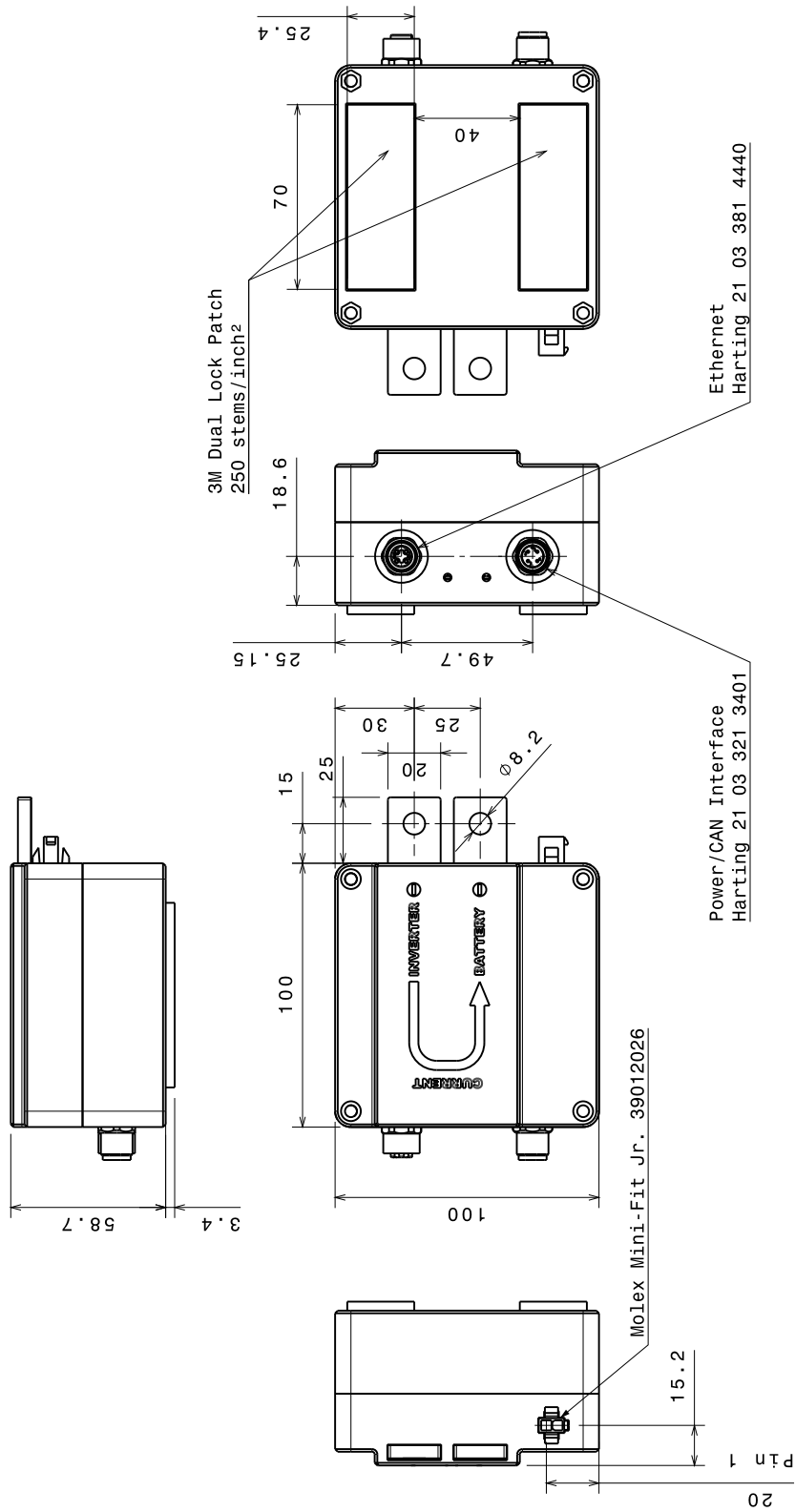

Figure 2: DL Mechanical Drawing