

CONTENTS

Changelog	3
Abbreviations	8
A Administrative Regulations	10
A1 Competition Overview	10
A2 Vehicle Eligibility	11
A3 Rules of Conduct	12
A4 General Requirements for Teams & Participants	13
A5 Documentation & Deadlines	15
A6 General Rules	18
T General Technical Requirements	22
T1 General Design Requirements	22
T2 General Chassis Design	25
T3 Cockpit	37
T4 Driver Restraint System	42
T5 Brake System	46
T6 Powertrain	47
T7 Aerodynamic Devices	48
T8 Compressed Gas Systems and High Pressure Hydraulics	50
T9 Fasteners	51
T10 Electrical Components	52
T11 Vehicle Identification	55
T12 Vehicle and Driver Equipment	56
CV Internal Combustion Engine Vehicles	59
CV1 Internal Combustion Engine Powertrains	59
CV2 Fuel and Fuel System	63
CV3 Exhaust System and Noise Control	66
CV4 Electric System and Shutdown System	67
EV Electric Vehicles	69
EV1 Electric System Definitions	69
EV2 Electric Powertrain	69
EV3 General Requirements	70
EV4 Grounded Low Voltage System (GLVS)	70
EV5 Tractive System (TS)	71
EV6 Tractive System Energy Storage	77
EV7 Shutdown Circuit and Systems	82
EV8 Chargers	85
EV9 Tractive System Procedures and Tools	86

Contents

EV 10 Electrical System Form (ESF)	87
DV Driverless Vehicles	88
DV 1 Vehicle Requirements and Restrictions	88
DV 2 Autonomous System (AS)	89
DV 3 Emergency Brake System (EBS)	92
DV 4 Sensors	94
IN Technical Inspections	95
IN 1 General	95
IN 2 Pre-Inspection	97
IN 3 [EV ONLY] Accumulator Inspection	98
IN 4 [EV ONLY] Electrical Inspection	99
IN 5 Mechanical Inspection	99
IN 6 [DV ONLY] Driverless Inspection	100
IN 7 Tilt Test	101
IN 8 Vehicle Weighing	101
IN 9 [EV ONLY] Rain Test	102
IN 10 [CV ONLY] Noise Test	102
IN 11 Brake Test	103
IN 12 Post Event Inspection	103
S Static Events	105
S 1 Business Plan Presentation Event (BPP)	105
S 2 Cost and Manufacturing Event	106
S 3 Engineering Design Event	110
D Dynamic Event Regulations	114
D 1 Dynamic Events General	114
D 2 Driving Rules	114
D 3 Weather Conditions	117
D 4 Skidpad Event	118
D 5 Acceleration Event	120
D 6 Autocross Event	121
D 7 Endurance and Efficiency Event	122
D 8 [DV ONLY] Trackdrive and Efficiency Event	127
D 9 Dynamic Events Penalties	128

CHANGELOG

Rule	Version	Change
A 2.2.1	1.0	Clarified first year vehicle.
A 2.3	1.0	Redefined old vehicle usage for Driverless Vehicle (DV).
A 3.7.1	1.0	Requests for informal review before protest must be filed within the protest period.
A 4.8.1	1.0	Maximum four Electrical System Officers (ESOs) allowed
A 4.9.2	1.0	Clarified that there are no additional ESOs
A 5.1.1	1.0	Charging Connector Deadline deleted.
A 5.6.3	1.0	Additional Vehicle Status Video (VSV) requirements for driverless.
A 5.6.3	1.1	Made file size limit competition-specific.
A 5.6.7	1.0	Clarified VSV deadline penalties.
A 5.6.8	1.0	Old vehicle on VSV leads to de-registration.
A 5.7.2	1.0	SES Approval (SESA) no longer possible by university professor.
A 6.7.6	1.0	Fireproof suit needed when vehicle is pushed around.
T 1.2.2	1.0	Added chassis/belly pan venting hole requirement
T 1.3.2	1.0	Moved from D 2.3
T 1.6.1	1.0	Clarified belt usage in DV steering.
T 2.1.1	1.0	Rearranged, definition for side impact structure, chassis, monocoque and rollover protection added
T 2.1.1	1.1	Rephrased the rule text
T 2.4.2	1.0	Changed the reference
T 2.6.1	1.0	Added test specifications
T 2.6.1	1.1	Rephrased rule text
T 2.6.3	1.0	Added rule for same lay-up with different core dimensions
T 2.6.3	1.1	Rephrased the rule text
T 2.6.4	1.0	Changed wording
T 2.6.5	1.0	Added test specification
T 2.6.5	1.1	Changed test specification
T 2.7.3	1.1	Added CAD detail requirements
T 2.8.4	1.0	Moved and added front hoop attachment requirements
T 2.8.5	1.0	Moved and added front hoop mounting plate requirements
T 2.8.6	1.1	Added position requirement straight
T 2.10.4	1.1	New rule laminating front hoop into monocoque
T 2.11.1	1.1	Rephrased the rule text
T 2.11.2	1.1	Rephrased the rule text
T 2.11.3	1.1	Rephrased the rule text
T 2.11.4	1.1	Rephrased the rule text
T 2.11.5	1.1	Rephrased the rule text
T 2.11.6	1.1	Rephrased the rule text
T 2.12.1	1.1	Rephrased the rule text
T 2.12.2	1.1	Rephrased the rule text

Contents

Rule	Version	Change
T2.12.3	1.0	Clarification: Complete front hoop bracing structure.
T2.12.4	1.1	Rephrased the rule text
T2.12.5	1.1	Rephrased the rule text
T2.14	1.0	Deleted redundant rules
T2.15.4	1.1	Deleted redundant text
T2.16.2	1.1	Deleted redundant text
T2.18.5	1.1	Added attachment clarification
T2.20.2	1.1	Shortened rule
T2.20.3	1.1	New rule
T2.20.5	1.1	Shortened rule
T2.20.6	1.1	New rule
T2.21.1	1.0	Changed wording and added extra requirement
T3.3.4	1.0	Changed wording
T3.7	1.1	Separated into different single rules
T3.8.3	1.0	Clarified fire resistant definition
T4.7.2	1.0	Changed material specification
T5.2.1	1.0	Added definition brake system failure
T6.3.4	1.0	Added temperature requirements and scale.
T6.4.1	1.1	Rephrased the rule text
T7.3.3	1.0	Length restriction for aerodynamic devices to the front added
T8.1.1	1.0	Changed wording protective envelope
T9.1.1	1.0	Added clarification
T10.1	1.0	Centralized requirements for master switches.
T10.1.3	1.0	Removed requirement of horizontal axis.
T10.2.4	1.0	Replaced "marine-type" by more specific requirements.
T10.2.8	1.0	LV battery management systems are SCS and the battery management must be inside the pack. LV battery management system must be able to display voltages and temperatures. Casing material requirements clarified.
T10.4.2	1.0	Clarification that cable connections and wireless connections are intended
T10.4.2	1.1	Added exception for SCS detections. (Exception was added in V1.0, but changelog was missing)
T10.4.3	1.1	Added definition for SCS. (Definition was added in V1.0, but changelog was missing)
T12.1.2	1.0	Added color requirement
T12.2	1.0	Added more specifications
T12.3.2	1.1	Added and changed certifications
CV1.1.1	1.0	Maximum engine displacement 710 cm ³
CV1.6.12	1.0	ETC Failure Modes and Effects Analysis (FMEA) replaced by template.
CV2.2	1.0	Moved for better document structure
CV2.2.3	1.1	Changed the distance requirement
CV2.6.1	1.0	Added material temperature requirement.
CV2.6.1	1.1	Rephrased rule text
CV3.1.3	1.0	Added surface temperature requirement.
CV4.2	1.0	Centralized some requirements for master switches.
CV4.2.3	1.0	Changed marking of master switch
EV	1.0	Rearranged rules and sections to improve readability.

Contents

Rule	Version	Change
EV 1	1.0	Removed definition of HV and LV systems and included all requirements in GLVS and TS.
EV 3.2.4	1.0	Exception for overcurrent protection of the output of commercially inverters.
EV 5.1.1	1.0	Added exception for inverter internal signals.
EV 5.1.3	1.0	Added requirement for proper temperature rating of TS components.
EV 5.2.1	1.0	Removed exception for stickers on motor housings.
EV 5.3.5	1.0	Clarified rule
EV 5.3.5	1.0	Added clarification that spacing exception is only valid for the IC but not for the whole PCB.
EV 5.3.6	1.0	Fully assembled spare boards must be presented. Pictures are not sufficient anymore.
EV 5.4.3	1.0	Defined that interlocks must open the shutdown circuit before TS wire break.
EV 5.5.2	1.0	Added requirement of rated voltage for insulation material.
EV 5.5.3	1.0	Centralized temperature requirement
EV 5.5.8	1.0	Added requirement that connections must be accessible or photographs must be available.
EV 5.6	1.0	Clean up of data logger section. Changed wording from “Energy Meter” to “Data Logger”
EV 5.6.2	1.0	Added time restriction for data logger accessibility.
EV 5.6.3	1.1	Prohibited data logger placement within the accumulator container.
EV 5.6.4	1.0	Clarification that the Data Logger has to be on the vehicle side of the most negative AIR.
EV 5.7.3	1.1	TSMP itself do not have a color restriction anymore.
EV 5.7.5	1.0	Changed marking from HV+ and HV- to TS+ and TS-
EV 5.7.5	1.1	TSMPs must be mounted on an orange background.
EV 5.9	1.0	Splitted sections for pre- and discharge circuits
EV 5.9.1	1.0	Change in wording for clarification.
EV 5.9.1	1.1	Clarification of rule.
EV 5.10.8	1.0	Removed parts of the exceptions for measurement connection.
EV 5.10.9	1.0	Added requirement for an “accumulator replacement device”.
EV 5.11.2	1.0	Added requirement that closing the shutdown circuit by its required parts must not activate the TS.
EV 5.11.5	1.0	Clarification
EV 5.11.6	1.0	Added clarification for leaving the ready-to-drive mode.
EV 5.12.2	1.0	Maximum sound level of 90 dBA for Ready-To-Drive sound
EV 6.3.6	1.0	Added requirement of contact details on accumulator container.
EV 6.4.3	1.0	Removed exception for BSPD.
EV 6.5.2	1.0	Clarification of wording.
EV 6.7	1.0	Splitted pre- and discharge circuit section
EV 6.7.1	1.0	Pre-Charge process must be supervised.
EV 6.8	1.0	Rework of AMS section
EV 6.8.6	1.0	Added maximum debounce time for AMS
EV 6.8.10	1.0	All values (not just the cell voltages) must be displayed by the AMS
EV 7.1.5	1.0	Delaying of opening the Accumulator Isolation Relays (AIRs) is allowed.
EV 7.2	1.0	Centralized some requirements for master switches.
EV 7.2.1	1.1	Clarification that each master switch be according to T 10.1
EV 7.2.3	1.0	Added requirement for locking the Tractive System Master Switch (TSMS).

Contents

Rule	Version	Change
EV 7.2.5	1.0	Changed marking of Grounded Low Voltage Master Switch (GLVMS)
EV 7.2.6	1.0	Changed marking of GLVMS
EV 7.2.7	1.0	Marking of TSMS
EV 7.2.8	1.0	Marking of TSMS
EV 7.5.1	1.0	Added “permanently” for clarification. Changed wording from “circuit” to “device”.
EV 7.5.2	1.0	BSPD standalone clarification.
EV 7.5.3	1.0	BSPD must be directly supplied by the GLVMS.
EV 7.5.4	1.0	BSPD must not be inside the accumulator container.
EV 7.5.8	1.0	The complete BSPD circuitry must be tested.
EV 8.1.6	1.0	Clarification of Insulation Monitoring Device (IMD) for chargers and IMD indicator light
EV 8.2.2	1.0	Opening the charging shutdown circuit must disable the charging process until manually reset.
EV 9.3.3	1.0	Adjusted rule to new accumulator label requirement.
DV 1.4.5	1.0	Summarized rules on RES usage and define ASR as RES operator.
DV 2.2	1.0	Changed marking of ASMS and clarified ASMS function.
DV 2.3.1	1.0	ASSI now three-part.
DV 2.3.3	1.0	Three-part ASSI position definitions.
DV 2.3.4	1.0	Three-part ASSI size definitions.
DV 2.3.4	1.1	ASSI background defined.
DV 2.4	1.0	Reworked AS states.
DV 2.5	1.0	Replaced AMI section by autonomous missions section.
DV 2.5.5	1.1	AMI as SCS, note on e-ink display.
DV 3.1.3	1.0	EBS passive
DV 3.1.7	1.0	Marking of EBS release.
DV 3.1.8	1.0	Forbid use of push-in fittings at EBS.
DV 3.2.1	1.0	The vehicle, not the EBS must come to the safe state.
DV 3.2.4	1.0	Clarified tractive system is no brake system
DV 3.2.5	1.0	Brake system may be redundancy to EBS.
DV 4.1.1	1.0	Radii for sensor mounts.
IN 1.6.1	1.0	Only adjustment of winglets but not complete aerodynamic device possible
IN 3.1.2	1.0	Changed word “will” to “must”
IN 3.2.2	1.0	clarified the amount of gloves
IN 3.2.2	1.0	Moved rule to accumulator inspection
IN 11.2.2	1.0	Updated rule to two color TSAL
IN 12.2.3	1.0	Post event inspection penalties event specific and in time rather than points
IN 12.2.5	1.0	Weight penalty points are deducted from overall competition score rather than design event score
S 1.2.5	1.0	HDMI connectors also available
S 1.3.2	1.0	Specified location of vehicle number
S 2.3.3	1.0	Added the need to bring two Cost Report Documents (CRD) to the discussion
S 2.3.6	1.0	Added penalty in case hard copy doesn’t match uploaded CRD
S 2.9.1	1.0	Changed point distribution for Cost scoring
S 3	1.0	Integrated autonomous design into engineering design.
D 1.1.4	1.0	DV need one driver.
D 2.3.2	1.0	DNF in case of ground clearance issue moved to IN 12.

Contents

Rule	Version	Change
D2.6	1.0	Defined DV start-up procedure.
D2.6.5	1.1	EBS can be armed in preparation area.
D2.7.3	1.0	ASR operates the RES.
D4.1.4	1.0	No more removable cone in skidpad.
D4.3.1	1.0	Leave the option to have more runs for DV events.
D4.4.1	1.0	Clarified skipdad penalties are added after averaging.
D4.4.3	1.0	T_{\max} increased for DV.
D4.4.4	1.0	T_{\max} increased for DV.
D5.1.2	1.0	Reduced track width for DV.
D5.4.3	1.0	Increased T_{\max} for DV.
D6.1.1	1.0	Reduce width to 3 m.
D7.4.6	1.0	New rule.
D8.3.1	1.0	Restricted course walk.
D8.3.1	1.1	Removed smartphones.
D9.1.4	1.0	DOO for trackdrive only once.
D9.4	1.0	Moved to penalty section.
D9.4.2	1.0	Clarified that the fastest run of the event is meant.
D9.4.3	1.0	Changed wording from “will” to “may”.
D9.4.4	1.0	Changed wording from “Energy Meter” to “Data Logger”.

ABBREVIATIONS

AAIR	ASF Add Item Request	EBS	Emergency Brake System
ADR	Autonomous Design Report	ECU	Electronic Control Unit
AIP	Anti Intrusion Plate	EDR	Engineering Design Report
AIR	Accumulator Isolation Relay	EI	Flexural Rigidity
AMI	Autonomous Mission Indicator	ESF	Electrical System Form
AMS	Accumulator Management System	ESO	Electrical System Officer
APPS	Accelerator Pedal Position Sensor	ESOQ	Electrical System Officer Qualification
AS	Autonomous System	ETC	Electronic Throttle Control
ASF	Autonomous System Form	EV	Electric Vehicle
ASMS	Autonomous System Master Switch	FMEA	Failure Modes and Effects Analysis
ASR	Autonomous System Responsible	FTO	Fuel Type Order
ASRQ	ASR Qualification	GLVMS	Grounded Low Voltage Master Switch
ASSI	Autonomous System Status Indicator	GLVS	Grounded Low Voltage System
BOM	Bill of Material	HPI	High Pressure Injection
BOTS	Brake Over-Travel Switch	HV	High Voltage
BPES	Business Plan Executive Summary	HVD	High Voltage Disconnect
BPP	Business Plan Presentation Event	IA	Impact Attenuator
BSE	Brake System Encoder	IAD	Impact Attenuator Data
BSPD	Brake System Plausibility Device	IMD	Insulation Monitoring Device
CBOM	Costed Bill of Material	LPI	Low Pressure Injection
CRD	Cost Report Documents	MO	Magazine Uploads
CV	Internal Combustion Engine Vehicle	OC	Off-course
DI	Direct Injection	OEM	Original Equipment Manufacturer
DNA	Did Not Attempt	PCB	Printed Circuit Board
DNF	Did Not Finish	RES	Remote Emergency System
DOO	Down or Out	RMS	Root Mean Square
DSS	Design Spec Sheet	SCS	System Critical Signal
DV	Driverless Vehicle	SE3D	Structural Equivalency 3D Model
EAIR	ESF Add Item Request	SES	Structural Equivalency Spreadsheet

Abbreviations

SESA	SES Approval	TSMP	Tractive System Measuring point
TMD	Team Member Designation	TSMS	Tractive System Master Switch
TPS	Throttle Position Sensor	USS	Unsafe Stop
TS	Tractive System	VSV	Vehicle Status Video
TSAL	Tractive System Active Light		

A ADMINISTRATIVE REGULATIONS

A 1 COMPETITION OVERVIEW

A 1.1 Competition Objective

A 1.1.1 The competition challenges teams of university students to conceive, design, fabricate, develop and compete with small, formula style, race cars.

A 1.2 Competition Procedure

A 1.2.1 The competition is split into the following classes:

- Internal Combustion Engine Vehicle (CV)
- Electric Vehicle (EV)
- Driverless Vehicle (DV) (which are either CV or EV)

A 1.2.2 All vehicles must meet the requirements defined in chapters T and either EV or CV, depending on their drivetrain type.

A 1.2.3 Vehicles from the DV class in addition, must meet the requirements defined in chapter DV.

A 1.2.4 The competition starts with a series of technical inspections described in chapter IN to check the vehicle for safety and compliance with the rules.

A 1.2.5 The competition is divided into a series of static and dynamic events described in chapters S and D.

A 1.2.6 Maximum points are awarded as described in Table 3.

A 1.2.7 The team with the most overall points will win the competition for its class.

A 1.3 Competition Information

A 1.3.1 The competition specific rules and information are defined in the competition handbook.

A 1.3.2 The official language of the competition is English.

A2 Vehicle Eligibility

	CV & EV	DV
Static Events:		
Business Plan Presentation	75 points	75 points
Cost and Manufacturing	100 points	100 points
Engineering Design	150 points	325 points
Dynamic Events:		
Skid Pad	75 points	75 points
Acceleration	75 points	75 points
Autocross	100 points	-
Endurance	325 points	-
Efficiency	100 points	100 points
Trackdrive	-	250 points
Overall	1000 points	1000 points

Table 3: Maximum points awarded

A2 VEHICLE ELIGIBILITY

A2.1 Student Competition

- A2.1.1 Vehicles entered into the competition must be conceived, designed and maintained by the student team members without direct involvement from professional engineers, racers, machinists or related professionals.
- A2.1.2 The student team may use any information from professionals or from academics as long as the information is given as a discussion of alternatives with their pros and cons.
- A2.1.3 Professionals may not make design decisions or drawings.
- A2.1.4 Students should perform fabrication tasks where ever possible.

A2.2 First Year Vehicles

- A2.2.1 A vehicle may only be used for one year, counting from the first day onsite of its first competition.
- A2.2.2 To be classified as new, a vehicle must have significant changes in the chassis structure to its predecessor.

A2.3 [DV ONLY] Base Vehicles

- A2.3.1 In derogation from A2.2, reconfigured vehicles from any year may participate in the DV class. This includes vehicles that have been participating in the DV class in the previous year if there are significant changes in the autonomous system.
- A2.3.2 All Driverless Vehicles (DVs) must be fully compliant with the current version of these rules.

A3 Rules of Conduct

A 3 RULES OF CONDUCT

A3.1 General Officials Authority

- A 3.1.1 The officials reserve the right to revise the schedule of the competition and/or interpret or modify the competition rules at any time and in any manner that is, in their sole judgment, required for safe and efficient operation.
- A 3.1.2 All team members are required to cooperate with, and follow all instructions from the officials.
- A 3.1.3 Official announcements shall be considered part of these rules.
- A 3.1.4 All guidelines and clarifications posted in the “Rules and Important Documents” sections on the competition website for the current season including the competition handbook are considered part of these rules.
- A 3.1.5 Questions concerning the meaning or intent of the rules will be resolved by the officials.

A3.2 Official Instructions

- A 3.2.1 Failure of a team member to follow an instruction or command directed specifically to that team or team member will result in a 25 point penalty.

A3.3 Arguments with Officials

- A 3.3.1 Argument with, or disobedience to, any official will result in the team being eliminated from the competition.

A3.4 Unsportsmanlike Conduct

- A 3.4.1 In the event of unsportsmanlike conduct, the team will receive a 25 point penalty. A second violation will result in expulsion of the team from the competition.

A3.5 Violations of Intent

- A 3.5.1 Violation of the intent of a rule will be considered a violation of the rule itself.

A3.6 Questions about the Rules

- A 3.6.1 Questions about the rules may be asked to the officials.
- A 3.6.2 The frequently asked questions (FAQ) section on the competition website must be checked before submitting a question.
- A 3.6.3 The officials will only answer questions that are not already answered in the rules or FAQs or that require new or novel interpretation.
- A 3.6.4 Refer to the competition website for specific directions how to submit a rules question.

A4 General Requirements for Teams & Participants

A 3.7 Protests

- A 3.7.1 If a team has a question about scoring, judging, policies or any official action it must be brought to the officials' attention within the announced protest period for an informal preliminary review before a protest can be filed.
- A 3.7.2 A team may protest any rule interpretation, score or official action which they feel has caused some actual, non-trivial, harm to their team, or has had a substantive effect on their score.
- A 3.7.3 All protests must be filed in writing and presented to the officials by the team captain. In order to have a protest considered, a team must post a 25 point protest bond which will be forfeited if their protest is rejected.
- A 3.7.4 The decision of the officials regarding any protest will be in a written form and is final.

A 4 GENERAL REQUIREMENTS FOR TEAMS & PARTICIPANTS

A 4.1 Teams per University

- A 4.1.1 A university may register a CV team, an EV team and a DV team.
- A 4.1.2 For the purposes of registering and competing, a university's CV team, EV team and DV team are considered to be separate and independent entities.
- A 4.1.3 Teams which are formed with members from two or more universities are treated as a single team.

A 4.2 Team Members

- A 4.2.1 A team member may only be part of one team, work on one vehicle and take part in static and dynamic events for only one team.
- A 4.2.2 Each team must have one team member identified as the team captain. The team captain is the main contact person for the officials during the registration process and the competition.

A 4.3 Student Status

- A 4.3.1 Team members must be enrolled as degree seeking undergraduate or graduate students in any university. Team members who have graduated within the seven month period prior to the competition remain eligible to participate.
- A 4.3.2 Students seeking a PhD degree/PhD students or equivalent are not allowed to participate.

A 4.4 Age

- A 4.4.1 Team members must be at least eighteen years of age.

A4 General Requirements for Teams & Participants

A 4.5 Driver's License

A 4.5.1 Team members who will drive a competition vehicle at any time during a competition must present a valid, government issued driver's license for passenger cars, containing a photograph.

A 4.6 Insurance

A 4.6.1 Each participant must provide proof of valid private liability & individual health insurance for the competition.

A 4.7 Liability Waiver

A 4.7.1 All onsite participants must sign a liability waiver upon registering onsite which can be found on the competition website.

A 4.8 [EV ONLY] Electrical System Officer (ESO)

A 4.8.1 Every participating team has to appoint one to four ESOs for the competition.

A 4.8.2 The ESOs are responsible for all electrical work carried out on the vehicle during the competition.

A 4.8.3 The ESOs are the only persons in the team who may declare the vehicle electrically safe, in order for work to be performed on any system of the vehicle by the team.

A 4.8.4 The ESOs must be valid team members, which means that they must have student status, see A 4.3.

A 4.8.5 The ESOs must be contactable by phone at all times during the competition.

A 4.8.6 An ESO must accompany the vehicle whenever it is operated or moved around at the competition site.

A 4.8.7 If only one ESO is named by the team, this ESO may not be a driver.

A 4.8.8 The ESOs must be properly qualified, must have basic knowledge of working safety and must be allowed to work on live HV systems.

A 4.8.9 The qualification details must be provided to the officials using the Electrical System Officer Qualification (ESOQ) form which is available on the competition website.

A 4.8.10 An appropriate ESO qualification is:

- Proof of appropriate practical and theoretical training for working with HV power systems by an external technical testing organization
- Qualified electrician
- Electrical engineer (or equivalent) bachelor title

A5 Documentation & Deadlines

A 4.9 [DV ONLY] Autonomous System Responsible (ASR)

- A 4.9.1 Every participating team must appoint at least one ASR for the competition. This person is responsible for all autonomous operations of the vehicle during the competition which includes any work on the autonomous system as well as racing and testing.
- A 4.9.2 For driverless vehicles with an electric drivetrain the ASR must fulfill A 4.8 and therefore replaces the ESO. The team may not register additional ESOs.
- A 4.9.3 The ASR is the only person in the team who is allowed to declare the autonomous system safe, so that work on any system of the vehicle may be performed by the team, or the vehicle may be operated in manual or autonomous mode.
- A 4.9.4 The ASR must be a valid team member, which means that he/she must have student status, see A 4.3.
- A 4.9.5 The ASR must accompany the vehicle whenever it is operated or moved around at the competition site.
- A 4.9.6 If only one ASR is named by the team, this ASR may not be a driver.
- A 4.9.7 The ASR must be properly qualified to handle the autonomous system and to understand and deal with problems and failures. A bachelor degree in computer science, electrical engineering, mechatronics, automation engineering, robotics or similar is a sufficient qualification.

A 5 DOCUMENTATION & DEADLINES

A 5.1 Required Documents and Forms

- A 5.1.1 The following documents and forms must be submitted by the action deadlines defined in the competition handbook:
- Group A:
IAD, SE3D, SES, SESA, [EV ONLY] EAIR & ESF, [DV ONLY] AAIR & ASF
 - Group B:
BPES, CRD, DSS, EDR, [DV ONLY] ADR
 - Group C:
TMD, MO, [CV ONLY] ETC & FTO, [EV ONLY] ESOQ, [DV ONLY] ASRQ
 - Group D:
VSV

A 5.2 Submission

- A 5.2.1 Uploaded documents may only be viewed by members of the submitting team, authorized judges and officials.
- A 5.2.2 By submitting documents via the competition website, the team agrees that they may be reproduced and distributed by the officials, in both complete and edited versions, for educational purpose.
- A 5.2.3 Documents that are largely incomplete or not readable will be considered as not submitted.

A5 Documentation & Deadlines

A 5.3 Late Submission or Non-Submission

- A 5.3.1 Submissions later than the initial deadline will be penalized by ten points for group A and B for every 24 hours they are overdue. These will be deducted from the team's overall score up to a maximum of 70 points for each deadline independently.
- A 5.3.2 Teams that submit documents which miss the initial deadlines of group A by more than 168 hours (7 days) will be de-registered from the competition.
- A 5.3.3 Teams that submit documents which miss the initial deadlines of group B by more than 168 hours (7 days) will receive zero points for the related event. In that case, no additional penalty points are given.

A 5.4 Correction Requests

- A 5.4.1 If the officials request a correction for a document in group A and the team has not uploaded a corrected version after 168 hours (7 days) following the request, it will be penalized by five points for every 24 hours they are overdue, up to a maximum of 35 points for each independent correction request. These points will be deducted from the team's overall score.
- A 5.4.2 The team will be de-registered from the competition if it has not uploaded a corrected version of a document of group A after 336 hours (14 days) following the request.
- A 5.4.3 Simultaneous requests for different parts within one document or form will be penalized independently of each other.

A 5.5 De-registration

- A 5.5.1 A team which is de-registered from the competition has a single chance to apply for a place on the waiting list.
- A 5.5.2 To apply, the team must complete the following within 24 hours after the de-registration notification
- Submit an informal application to the officials
 - Correct the reason for de-registration (e.g. upload of a document)
- A 5.5.3 If the application is positively confirmed by the officials, the team will be
- Placed at the end of the waiting list
 - Receive the full amount of penalties for the offense
- A 5.5.4 Applications will be declined if the rework is inadequate or de-registration was caused by misbehavior of the team.

A 5.6 Vehicle Status Video (VSV)

- A 5.6.1 All teams must upload a video showing the vehicle driving prior to the competition. The video must be uploaded before the deadline specified in the competition handbook.
- A 5.6.2 The video must show the following sequences:

A5 Documentation & Deadlines

- Standing still (video close-up of the vehicle front left-side; min. 70 %)
- Straight driving
- 180° cornering
- Straight driving back to start point
- Standing still (video close-up of the vehicle front right-side; min. 70 %)

A 5.6.3 The video must fulfill the following criteria:

- Continuous video from a third person view - no assembled sequences
- Vehicle must be clearly visible (light, video resolution, frames and frequency)
- Vehicle must run under its own power
- Driving in a clearly separated and/or protected area (A 6.4 applies)
- Vehicle must be presented in ready-to-race conditions incl. body work
- Driver must wear equipment as specified in the rules, incl. helmet, driver suit, gloves and arm-restraints
- [EV ONLY] Tractive System Active Light (TSAL) must be clearly visible in the video
- [EV ONLY] Ready-to-drive sound must be audible in the video
- [DV ONLY] Vehicle must drive without a driver
- [DV ONLY] Autonomous System Status Indicator (ASSI) must be clearly visible in the video
- [DV ONLY] In addition to the third person view, an onboard view and a visualization of the vehicle's environment perception and path planning must be shown in split screen. All parts must be time synchronized.
- [DV ONLY] At the end of the VSV, the vehicle must be stopped by an emergency brake maneuver (see DV 3).
- Must not exceed a length of 45 seconds. File size may be limited by the competition (website).
- File format must be common e.g. avi, mpg, mp4, wmv

A 5.6.4 The VSV will be reviewed in order of submission. A review may take up to two weeks.

A 5.6.5 If a team receives a “fail” for its video prior to the VSV deadline, the video will be treated as not submitted. A new upload is possible afterwards.

A 5.6.6 Each team without a video upload prior to the specified deadline will receive ten penalty points. Furthermore, the team will receive three penalty points for each additional 24 hours the upload is late. The last upload of a video is possible 336 hours (14 days) after the VSV deadline (max. 49 penalty points). Teams without a video at this point will be de-registered from the competition. A re-entry will not be possible.

A 5.6.7 If a team receives a “fail” for its video after the VSV deadline, the team has to improve the video and upload it again for a new review. This must be done within 72 hours from the point of notification to not receive further penalties. If this period is missed, but the video is uploaded until 336 hours (14 days) after the VSV deadline, the team will receive 49 penalty points. If the uploaded video shows an appropriate running vehicle, but does not fulfill the

A 6 General Rules

criteria from A 5.6.2 and A 5.6.3 completely the team will receive five additional penalty points. These will be deducted from the team's overall score. If no new video is uploaded by then or the new video fails the review again, the team will be de-registered from the competition. A 5.5 does not apply in this case.

A 5.6.8 A team which uploads a VSV with a previous year vehicle will be de-registered from the competition.

A 5.7 SES Approval (SESA)

A 5.7.1 Teams using a monocoque chassis must submit a SESA as one document, in addition to the SES deadline. The SESA template will be available on the competition website.

A 5.7.2 The Structural Equivalency Spreadsheet (SES) must be checked and approved by:

- Validation/inspection organization (e.g. DEKRA, ...)
- Engineering firm for lightweight structures
- Engineering consultancy company
- Any other official competition

A 5.7.3 Once the SES has been approved by one of the listed institutions the SESA form should be filled out, signed by this institution and uploaded until the SESA deadline.

A 5.7.4 If any changes to the original SES become necessary due to the approval process, the updated final SES must be uploaded again on the competition website.

A 5.7.5 The changelog with details of all changes made from the "Version History" tab of the SES form must be attached to the SESA document and must also be signed by the SES reviewer.

A 5.7.6 The officials will randomly double check submitted SESA with their respective submitted SES.

A 6 GENERAL RULES

A 6.1 Removing the Vehicle from the Site

A 6.1.1 Teams who remove their vehicle ([EV ONLY] or tractive system accumulator) from the competition site after the competition has begun will be disqualified from the competition.

A 6.2 Forfeit for Non-Appearance

A 6.2.1 It is the responsibility of each team to be in the right place at the right time.

A 6.2.2 If a team is not present and ready to compete at the scheduled time, they forfeit their attempt at that event.

A 6.3 Team Briefings

A 6.3.1 All team captains and drivers on a particular day must attend the team briefing for that day.

A 6 General Rules

A 6.3.2 [DV ONLY] Drivers that want to operate a Driverless Vehicle (DV) in manual mode on the test track are required to attend the team briefing as well.

A 6.3.3 [DV ONLY] All ASR are required to attend the the team briefing.

A 6.4 Testing and Work Safety

A 6.4.1 Competition organizers are not responsible for the use of the vehicles outside of their competition.

A 6.4.2 The competition officials disassociate themselves from all activities of the teams besides their own competition and associated events.

A 6.4.3 All teams are advised to follow common practices and common sense when working on the vehicle and when operating the vehicle, before, during and after a competition.

A 6.4.4 The vehicles must not participate in events not suitable for this type of vehicles like hill climbs, drag races or similar.

A 6.4.5 Teams must never use their vehicles for wheel-to-wheel races.

A 6.4.6 The following listed requirements are considered the minimum for a testing/operating environment to qualify as safe. Following these guidelines does not guarantee safety under all circumstances:

- Driver wearing full protection gear incl. arm restraints
- Working TSAL, IMD, AMS, ASSI, RES, EBS, APPS/brake pedal plausibility check, APPS, and ETC plausibility check if applicable
- Rules compliant chassis and mounted impact attenuator
- No other passenger cars, trucks etc. being parked or driven on the same premise at the same time, unless the areas are clearly separated
- No running under low visibility conditions
- No running at speeds above typical event speeds
- No running in areas where crashing into obstacles at the height of the driver's head is possible, such that parts of the vehicle may pass below an obstacle, but the driver's head can be trapped between the obstacle and the main hoop for example.

A 6.4.7 Organizers reserve the right to disqualify a team registered for their competition in case of unsafe driving behavior, especially if the reputation of the competition, sponsors and other teams is compromised.

A 6.5 Onsite Working Safety

A 6.5.1 Everyone in the dynamic area and everybody working on the vehicle must wear appropriate, closed-toed shoes.

A 6.5.2 When using metal cutting equipment, eye protection is required for the operator as well as any team member assisting.

A 6.5.3 When operating loud tools, hearing protection is required.

A 6 General Rules

- A 6.5.4 Any operation producing litter or debris, e.g. cutting of carbon fiber, should not be performed in the pits.
- A 6.5.5 When jacking up the vehicle a safe and stable support device rated for the load must be used.
- A 6.5.6 The use of motorcycles, quads, bicycles, scooters, skateboards, rollerblades or similar mobility devices by team members and spectators in any part of the competition area is prohibited.
- A 6.5.7 The use of self-propelled pit carts, tool boxes, tire carriers or similar motorized devices in any part of the competition site is prohibited.

A 6.6 Alcohol and Illegal Material

- A 6.6.1 Alcohol, illegal drugs, weapons or other illegal material are prohibited on the competition site during the competition.
- A 6.6.2 If any team member is tested with an alcohol level higher than 0.0‰, he or she will be immediately disqualified for the rest of the competition. A second team member being found to have an alcohol level higher than 0.0‰ will result in the entire team being disqualified immediately.

A 6.7 Vehicle Movement

- A 6.7.1 Vehicles must not move under their own power anywhere other than on the practice or competition tracks.
- A 6.7.2 [EV ONLY] The detachable handle or key of the TSMS must be completely removed and kept by an ESO. The lockout/tagout function of the TSMS, see EV 7.2.3, must be used.
- A 6.7.3 [EV ONLY] If the vehicle has not passed electrical inspection, the High Voltage Disconnect (HVD), see EV 5.8, must be disconnected, while the vehicle is moved around on the competition site. This also includes taking part in static events.
- A 6.7.4 [DV ONLY] Driverless vehicles must also have their autonomous system (see definition in section DV 2.2) deactivated when being moved around the paddock. The detachable handle or key of the Autonomous System Master Switch (ASMS) must be completely removed and kept by an ASR. The lockout/tagout function of the ASMS, see DV 2.2.9, must be used.
- A 6.7.5 Vehicles must be pushed at a normal walking pace by means of a “pushbar” (see T 12.1) and with a team member in the cockpit wearing the required driver equipment as defined in T 12.3.1.
- A 6.7.6 The team member in the cockpit must wear a fireproof suit as per T 12.3.4 and have full control of steering and braking.
- A 6.7.7 When the pushbar is attached to the vehicle, the engine/tractive system must remain switched off.
- A 6.7.8 Vehicles with wings are required to have two team members walking on either side of the vehicle whenever the vehicle is being pushed.

A 6 General Rules

A 6.8 [CV ONLY] Engine Running

A 6.8.1 Running engines is not allowed in the pits.

A 6.8.2 Engine running is allowed in the engine test area and in the dynamic area, when the following conditions are met:

- The vehicle must have passed mechanical inspection.
- The vehicle must be jacked up using a quick jack (see T 12.2).
- A driver, wearing required driver equipment (see T 12.3.1), must be seated in the cockpit.
- A fire extinguisher must be immediately available.
- Driven wheels can only remain fitted to the vehicle if they will not rotate.
- No one is allowed under the vehicle while the engine is running.

A 6.9 Fueling and Oil

A 6.9.1 Fueling may only take place at the fuel station and must be conducted by officials only.

A 6.9.2 Open fuel containers are not permitted at the competition.

A 6.9.3 Waste oil must be taken to the fuel station for disposal.

T GENERAL TECHNICAL REQUIREMENTS

T1 GENERAL DESIGN REQUIREMENTS

T1.1 Vehicle Configuration

- T1.1.1 The vehicle must be designed and fabricated in accordance with good engineering practices.
- T1.1.2 The vehicle must be open-wheeled, single seat and open cockpit (a formula style body) with four wheels that are not in a straight line.
- T1.1.3 Open wheel vehicles must satisfy (see also Figure 1):
 - (a) The wheels/tires must be unobstructed when viewed from the side.
 - (b) No part of the vehicle may enter a keep-out-zone defined by two lines extending vertically from positions 75 mm in front of and 75 mm behind the outer diameter of the front and rear tires in the side view of the vehicle, with tires steered straight ahead. This keep-out zone extends laterally from the outside plane of the wheel/tire to the inboard plane of the wheel/tire.

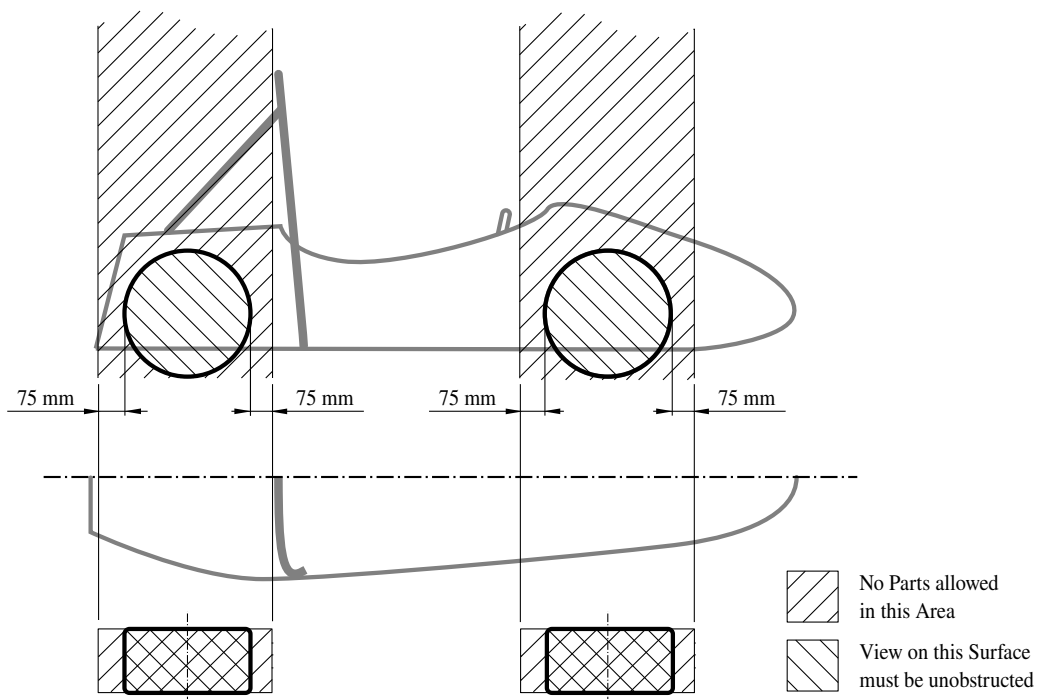

Figure 1: Keep-out-zones for the definition of an open-wheeled vehicle.

T1 General Design Requirements

T1.2 Bodywork

- T1.2.1 There must be no openings through the bodywork into the driver compartment other than that required for the cockpit opening. Minimal openings around the front suspension and steering system components are allowed.
- T1.2.2 Enclosed chassis structures and structures between the chassis and the ground must have two venting holes of at least 25 mm diameter in the lowest part of the structure to prevent accumulation of flammable liquids. Additional holes are required when multiple local lowest parts exist in the structure.
- T1.2.3 All edges of the bodywork that could come into contact with a pedestrian must have a minimum radius of 1 mm. The bodywork in front of the front wheels must have a radius of at least 38 mm extending at least 45° relative to the forward direction, along the top, sides and bottom of all affected edges.

T1.3 Suspension

- T1.3.1 The vehicle must be equipped with fully operational front and rear suspension systems including shock absorbers and a usable wheel travel of at least 50 mm with driver seated (25 mm jounce and 25 mm rebound).
- T1.3.2 The minimum static ground clearance of any portion of the vehicle, other than the tires, including a driver, must be a minimum of 30 mm.
- T1.3.3 All suspension mounting points must be visible at technical inspection, either by direct view or by removing any covers.

T1.4 Wheels

- T1.4.1 Any wheel mounting system that uses a single retaining nut must incorporate a device to retain the nut and the wheel in the event that the nut loosens. A second nut (“jam nut”) does not meet these requirements.
- T1.4.2 Standard wheel lug bolts and studs must be made of steel and are considered engineering fasteners. Teams using modified lug bolts, studs or custom designs will be required to provide proof that good engineering practices have been followed in their design.
- T1.4.3 Aluminum wheel nuts may be used, but they must be hard anodized and in pristine condition.

T1.5 Tires

- T1.5.1 Vehicles must have two types of tires as follows:
- (a) Dry tires - The tires on the vehicle when it is presented for technical inspection are defined as its “dry tires”.
 - (b) Wet tires - Wet tires may be any size or type of treaded or grooved tire provided:
 - The tread pattern or grooves were molded in by the tire manufacturer or were cut by the tire manufacturer or their appointed agent. Any grooves that have been cut must have documentary proof that it was done in accordance with these rules.

T1 General Design Requirements

- There is a minimum tread depth of 2.4 mm.

- T1.5.2 Tires on the same axle must have the same manufacturer, size and compound.
- T1.5.3 Tire warmers are not allowed.
- T1.5.4 Special agents that increase traction may not be added to the tires or track surface.

T1.6 Steering

- T1.6.1 Steering systems using cables or belts for actuation are prohibited.
[DV ONLY] This does not apply for autonomous steering actuators.
- T1.6.2 The steering wheel must be mechanically connected to the front wheels.
- T1.6.3 The steering system must have positive steering stops that prevent the steering linkages from locking up. The stops must be placed on the rack and must prevent the tires and rims from contacting any other parts.
- T1.6.4 Allowable steering system free play is limited to a total of 7° measured at the steering wheel.
- T1.6.5 The steering wheel must be attached to the column with a quick disconnect. The driver must be able to operate the quick disconnect while in the normal driving position with gloves on.
- T1.6.6 The steering wheel must be no more than 250 mm rearward of the front hoop. This distance is measured horizontally, on the vehicle centerline, from the rear surface of the front hoop to the forward most surface of the steering wheel with the steering in any position.
- T1.6.7 The steering wheel must have a continuous perimeter that is near circular or near oval. The outer perimeter profile may have some straight sections, but no concave sections.
- T1.6.8 In any angular position, the top of the steering wheel must be no higher than the top-most surface of the front hoop.
- T1.6.9 The steering rack must be mechanically attached to the chassis.
- T1.6.10 Joints between all components attaching the steering wheel to the steering rack must be mechanical and visible at technical inspection. Bonded joints without a mechanical backup are not permitted. The mechanical backup must be designed to solely uphold the functionality of the steering system.
- T1.6.11 Rear wheel steering, which can be electrically actuated, is permitted if mechanical stops limit the range of angular movement of the rear wheels to a maximum of 6° . This must be demonstrated with a driver in the vehicle and the team must provide the equipment for the steering angle range to be verified at technical inspection.

T1.7 Wheelbase

- T1.7.1 The vehicle must have a wheelbase of at least 1525 mm.

T2 General Chassis Design

T1.8 Track and Rollover Stability

- T1.8.1 The smaller track of the vehicle (front or rear) must be no less than 75 % of the larger track.
- T1.8.2 The track and center of gravity of the vehicle must combine to provide adequate rollover stability.

T2 GENERAL CHASSIS DESIGN

T2.1 Definitions

T2.1.1 The following definitions apply throughout this document:

- Chassis - The fabricated structural assembly that supports all functional vehicle systems. This assembly may be a single welded structure, multiple welded structures or a combination of composite and welded structures.
- Chassis member - A minimum representative single piece of uncut, continuous tubing or equivalent structure.
- Tube frame - A chassis made of metal tubes.
- Monocoque - A chassis made of composite material.
- Main hoop - A roll bar located alongside or just behind the driver's torso.
- Front hoop - A roll bar located above the driver's legs, in proximity to the steering wheel.
- Roll hoops - Both the front hoop and the main hoop are classified as "roll hoops"
- Roll hoop bracing - The structure from a roll hoop to the roll hoop bracing support.
- Roll hoop bracing supports - The structure from the lower end of the roll hoop bracing back to the roll hoop(s).
- Front bulkhead - A planar structure that defines the forward plane of the chassis and provides protection for the driver's feet.
- Impact Attenuator (IA) - A deformable, energy absorbing device located forward of the front bulkhead.
- Side impact structure - The area of the side of the chassis between the front hoop and the main hoop and from the chassis floor to the height as required in T2.16 above the lowest inside chassis point between front hoop and main hoop.
- Primary structure - The primary structure is comprised of the following components:
 - Main hoop
 - Front hoop
 - Roll hoop braces and supports
 - Side impact structure
 - Front bulkhead
 - Front bulkhead support system

T2 General Chassis Design

- All chassis members, guides and supports that transfer load from the driver's restraint system into the above mentioned components of the primary structure
- Rollover protection envelope - Envelope of the primary structure and any additional structures fixed to the primary structure which meet the minimum specification defined in T2.3 or equivalent.
- Node-to-node triangulation - An arrangement of chassis members projected onto a plane, where a co-planar load applied in any direction, at any node, results in only tensile or compressive forces in the chassis members as shown in Figure 2.

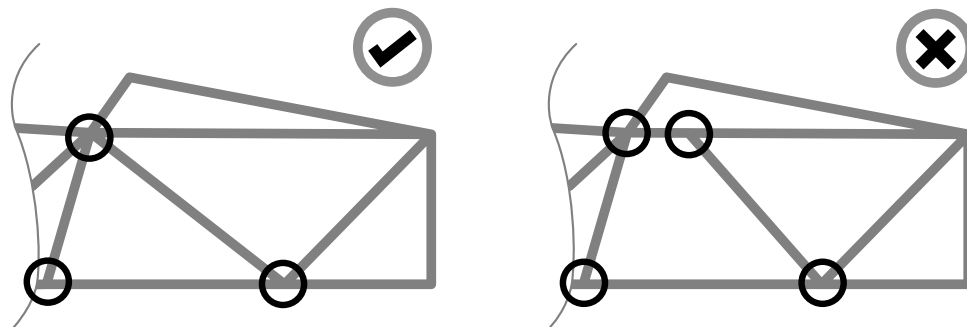

Figure 2: Node-to-node triangulation of chassis members (left correct and right incorrect).

T2.2 General Requirements

T2.2.1 Among other requirements, the vehicle's structure must include:

- Two roll hoops that are braced
- A front bulkhead with support system and Impact Attenuator (IA)
- Side impact structures

T2.3 Minimum Material Requirements

T2.3.1 Table 4 shows the minimum requirements for the members of the primary structure if made from steel tubing.

T2.3.2 Except for inspection holes (see T2.8.6), any holes drilled in any tube which is a member of the primary structure must show proof of equivalency in the SES.

T2.3.3 The steel properties used for the calculations in the SES must be:

Non-welded strength for continuous material calculations:

- Young's Modulus (E) = 200 GPa
- Yield Strength (S_y) = 305 MPa
- Ultimate Strength (S_u) = 365 MPa

T2 General Chassis Design

Item or application	Minimum wall thickness	Minimum area moment of inertia
Main and front hoops, shoulder harness mounting bar	2.0 mm	11 320 mm ⁴
Side impact structure, front bulkhead, roll hoop bracing, driver's restraint harness attachment (except as noted above) EV: Accumulator protection structure	1.2 mm	8509 mm ⁴
Front bulkhead support, main hoop bracing supports EV: Tractive system components	1.2 mm	6695 mm ⁴

Table 4: Minimum Material Requirements

Welded strength for discontinuous material such as joint calculations:

- Yield Strength (S_y) = 180 MPa
- Ultimate Strength (S_u) = 300 MPa

T2.3.4 Any tubing with a wall thickness less than 1.2 mm or a minimum area moment of inertia less than 6695 mm⁴ is considered non-structural and will be ignored when assessing compliance to any rule regarding the vehicle structure.

T2.3.5 If a member of the primary structure (except for the roll hoops) is a bent tube or made from multiple tubes an additional tube must support it. This support tube must:

- Have its attachment point at the position along the bend tube where it deviates farthest from a straight line connecting both ends.
- Be of the same dimension as the supported tube(s).
- Terminate at a node of the chassis.
- Be angled no more than 30° from the plane of the supported tube(s).

T2.4 Alternative Materials

T2.4.1 Alternative materials may be used for all parts of the primary structure and the tractive system accumulator container with the following exceptions:

- The main hoop and the main hoop bracing must be steel
- The front hoop must be metal
- Any welded structures of the primary structure must be steel
- However, the front hoop may be an aluminum welded structure

T2.4.2 If any other materials than steel tubing are used in the primary structure or the tractive system accumulator container, physical testing is required to show equivalency to the minimum material properties for steel in T2.3.

T2 General Chassis Design

T2.5 Composite Structures

- T2.5.1 If composite structures are used in the primary structure or the tractive system accumulator container, the Flexural Rigidity (EI) of that structure must be calculated as the EI of a flat panel about its neutral axis. This panel must have the same composition as the structure used in the chassis. The curvature of the panel and geometric cross section of the monocoque must be ignored for these calculations.
- T2.5.2 If composite materials are used in the primary structure or the tractive system accumulator container the SES must include:
- (a) Material type(s)
 - (b) Cloth weights
 - (c) Resin type
 - (d) Fiber orientation
 - (e) Number of layers
 - (f) Core material
 - (g) Lay-up technique
 - (h) 3-point-bend test and shear test data

T2.6 Laminate Testing

- T2.6.1 If composite materials are used for any part of the primary structure or the tractive system accumulator container the team must:
- Build a representative test panel which must measure exactly 275 mm × 500 mm that has the same design, laminate and fabrication method as used for the respective part of the primary structure represented as a flat panel. The sides of the test panel must not be laminated (core material must be visible).
 - Perform a 3-point bending test on this panel
- The data from these tests and pictures of the test samples and test setup, in which the dimensions between the two supports and load applicator are visible, must be included in the SES. The test results must be used to derive strength and stiffness properties used in the SES formula for all laminate panels.
- T2.6.2 If a panel represents side impact structure it must be proven that it has at least the same properties as two steel tubes meeting the requirements for side impact structure tubes for buckling modulus, yield strength and absorbed energy.
- T2.6.3 Composite structures with different core thicknesses but otherwise identical construction may use material properties derived from a single test panel.
- T2.6.4 The test samples must be presented at technical inspection.
- T2.6.5 The distance between the two test panel supports must be at least 400 mm.
- T2.6.6 The load applicator used to test any panel or tube must be metallic and have a radius of 50 mm.

T2 General Chassis Design

- T2.6.7 The load applicator must overhang the test piece to prevent edge loading.
- T2.6.8 There must be no material between the load applicator and the test piece.
- T2.6.9 Perimeter shear tests must be completed which measure the force required to push or pull a 25 mm diameter flat punch through a flat laminate sample. The sample must be at least 100 mm × 100 mm. Core and skin thicknesses must be identical to those used in the actual chassis structure and be manufactured using the same materials and processes.
- T2.6.10 The test fixture must support the entire sample, except for a 32 mm hole aligned co-axially with the punch. The sample must not be clamped to the fixture.

T2.7 Structural Documentation

- T2.7.1 All teams must submit a Structural Equivalency Spreadsheet (SES) and Structural Equivalency 3D Model (SE3D).
- T2.7.2 The SES spreadsheet form can be downloaded from the competition website.
- T2.7.3 The SE3D must contain a three dimensional CAD model of the chassis including all members of the primary structure and all mechanical attachment details of the hoops and hoop braces in “IGES” file format not larger than 40 MB. [EV ONLY] The accumulator container(s) and attachment must also be included.
- T2.7.4 Vehicles must be fabricated in accordance with the materials and processes described in the SES.
- T2.7.5 Teams must bring a copy of the approved SES to technical inspection.

T2.8 Roll Hoops

- T2.8.1 Both roll hoops must be securely integrated to the primary structure using node-to-node triangulation or equivalent joining methods.
- T2.8.2 The minimum radius of any bend, measured at the tube centerline, must be at least three times the tube outside diameter. Bends must be smooth and continuous with no evidence of crimping or wall failure.
- T2.8.3 The roll hoops must extend from the lowest chassis member on one side of the chassis, up, over and down to the lowest chassis member on the other side.
- T2.8.4 Roll hoops attached to a composite primary structure must be mechanically attached at the top and bottom of both sides of the structure and at intermediate locations if needed to show equivalency.
- T2.8.5 Mounting plates welded to the roll hoops must be at least 2 mm thick steel or 3 mm thick aluminum, dependent of the roll hoop material.
- T2.8.6 Both roll hoops must have one 4.5 mm hole in a non-critical straight location and its surface at this point must be unobstructed for at least 180°.

T2 General Chassis Design

T2.9 Main Hoop

- T2.9.1 The main hoop must be constructed of a single piece of uncut, continuous, closed section steel tubing.
- T2.9.2 In side view the portion of the main hoop which is above its upper attachment point to the side impact structure must be inclined less than 10° from vertical.
- T2.9.3 In side view any bends in the main hoop above its upper attachment point to the primary structure must be braced to a node of the main hoop bracing support structure with tubing meeting the requirements of main hoop bracing.
- T2.9.4 In side view any portion lower than the upper attachment point to the side impact structure must be inclined either forward or not more than 10° rearward.

T2.10 Front Hoop

- T2.10.1 If the front hoop is made from more than one piece it must be supported by node-to-node triangulation or an equivalent construction.
- T2.10.2 In side view, no part of the front hoop can be inclined more than 20° from vertical.
- T2.10.3 If the front hoop is a welded construction made from multiple aluminum profiles, the equivalent yield strength must be considered in the as-welded condition unless the team demonstrates and shows proof that it has been properly solution heat treated and artificially aged. The team must supply sufficient documentation proving the appropriate heat treatment process was performed.
- T2.10.4 Fully laminating the front hoop into the monocoque is acceptable. Equivalence to at least four mounts compliant with T2.17.1 must be shown in the SES.

T2.11 Main Hoop Bracing

- T2.11.1 The main hoop must be supported to the front or the rear by bracing tubes on each side of the main hoop.
- T2.11.2 In side view the main hoop and the main hoop braces must not lie on the same side of a vertical line coincident with the top of the main hoop.
- T2.11.3 The main hoop braces must be attached to the main hoop no lower than 160 mm below the top-most surface of the main hoop. The included angle formed by the main hoop and the main hoop braces must be at least 30°.
- T2.11.4 The main hoop braces must be straight.
- T2.11.5 The lower ends of the main hoop braces must be supported back to the upper attachment point of the main hoop to the side impact structure and to the lower attachment point of the main hoop to the side impact structure by a node-to-node triangulated structure or equivalent composite structure.
- T2.11.6 If any item which extends outside of the primary structure is attached to the main hoop braces, additional bracing is required to prevent bending loads in a rollover situation.

T2 General Chassis Design

T2.12 Front Hoop Bracing

- T2.12.1 The front hoop must be supported by two braces extending forward on each side of the front hoop.
- T2.12.2 The front hoop braces must extend to the structure forward of the driver's feet.
- T2.12.3 The front hoop bracing structure must be attached no lower than 50 mm below the top-most surface of the front hoop (see Figure 3).
- T2.12.4 If the front hoop is inclined more than 10° to the rear, additional braces extending rearwards are required.
- T2.12.5 The front hoop braces must be straight.

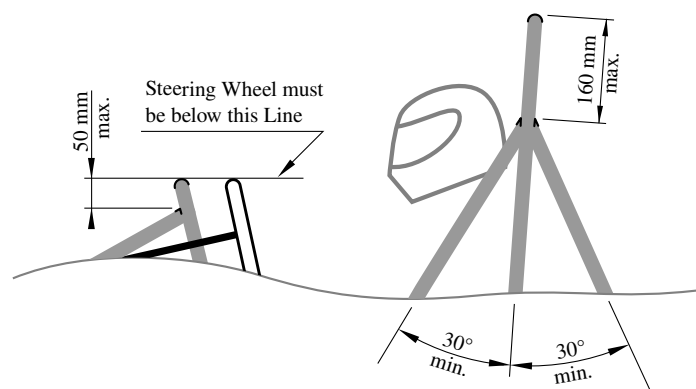

Figure 3: Front hoop bracing, main hoop bracing and steering wheel requirements

T2.13 Mechanically Attached Roll Hoop Bracing

- T2.13.1 Any non-welded joint at either end of a bracing must be either a double-lug joint (see Figure 4) or a sleeved joint (see Figure 5).
- T2.13.2 If threaded fasteners are used they are considered critical fasteners and must comply with T9.1.
- T2.13.3 Spherical rod ends are prohibited.
- T2.13.4 Double lug-joints must include a capping arrangement, see Figure 4.
- T2.13.5 In a double-lug joint each lug must be at least 4.5 mm thick and the pin or bolt must be 10 mm metric grade 8.8 minimum. The attachment holes in the lugs and in the attached bracing must be a close fit with the pin or bolt.
- T2.13.6 For sleeved joints the sleeve must have a minimum length of 38 mm either side of the joint and be a close-fit around the base tubes. The wall thickness of the sleeve must be at least that of the bracing tubes. The bolts must be 6 mm metric grade 8.8 minimum. The holes in the sleeves and tubes must be a close-fit with the bolts.

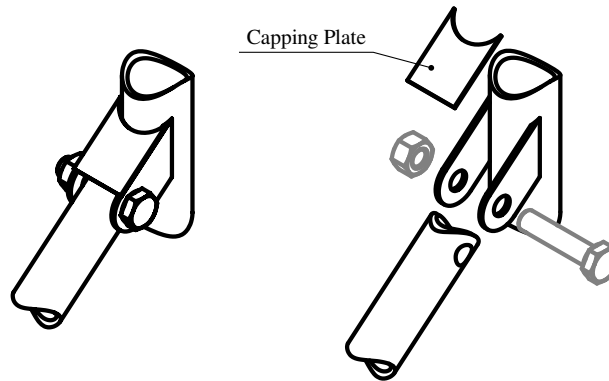

Figure 4: Double lug joint

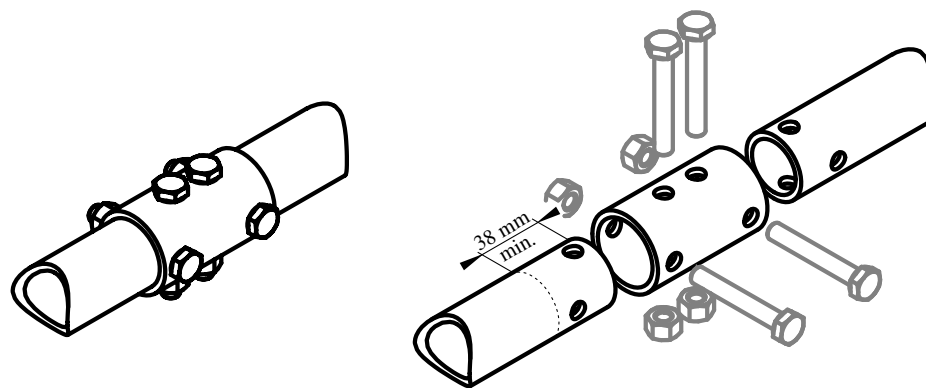

Figure 5: Sleeved joint

T2.14 Front Bulkhead

- T2.14.1 Any alternative material used for the front bulkhead must have a perimeter shear strength equivalent to a 1.5 mm thick steel plate.
- T2.14.2 If the front bulkhead is part of a composite structure and is modeled as an “L” shape, the EI of the front bulkhead about the vertical and lateral axes must be equivalent to a steel tube meeting the requirements for the front bulkhead. The length of the section perpendicular to the bulkhead may be a maximum of 25 mm measured from the rearmost face of the bulkhead.

T2.15 Front Bulkhead Support

- T2.15.1 The front bulkhead must be supported back to the front hoop by a minimum of three tubes on each side; an upper member, a lower member and diagonal bracing to provide triangulation.
- The upper support member must be attached to the front bulkhead a maximum of 50 mm below the top-most surface of the front bulkhead, and attached to the front hoop a maximum of 50 mm below the upper side impact member. If the attachment point of the upper member is greater than 100 mm above the upper side impact member, node-to-node triangulated bracing is required to transfer load to the main hoop.
 - The lower support member must be attached to the base of the front bulkhead and the base of the front hoop.

T2 General Chassis Design

- The diagonal bracing must triangulate the upper and lower support members node-to-node.
- T2.15.2 If the front bulkhead support is part of a composite structure, it must have equivalent EI to the sum of the EI of the six baseline steel tubes that it replaces.
- T2.15.3 The EI of the vertical side of the front bulkhead support structure must be equivalent to at least the EI of one baseline steel tube that it replaces.
- T2.15.4 The perimeter shear strength of the monocoque laminate in the front bulkhead support structure must be at least 4 kN.

T2.16 Side Impact Structure

- T2.16.1 The side impact structure must consist of at least three steel tubes (see T2.3) on each side of the cockpit (see Figure 6).
- The upper member must connect the main hoop and the front hoop. It must be at a height between 240 mm and 320 mm above the lowest inside chassis point between the front and main hoop.
 - The lower member must connect the bottom of the main hoop and the bottom of the front hoop.
 - The diagonal member must triangulate the upper and lower member between the roll hoops node-to-node.

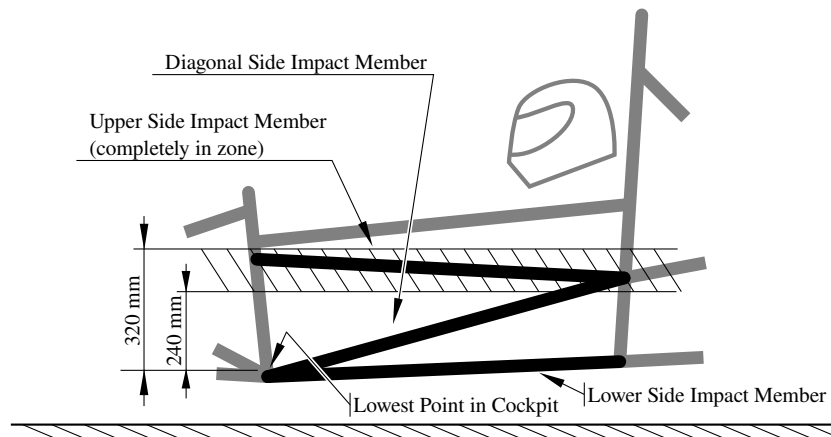

Figure 6: Side impact structure tube frame

- T2.16.2 If the side impact structure is part of a composite structure, the following is required:
- The region that is longitudinally forward of the main hoop and aft of the front hoop and vertical from the bottom surface of the chassis to 320 mm above the lowest inside chassis point between the front and main hoop must have an EI equal to the three baseline steel tubes that it replaces (see Figure 7).
 - The vertical side impact structure must have an EI equivalent to two baseline steel tubes and half the horizontal floor must have an EI equivalent to one baseline steel tube.

T2 General Chassis Design

- The vertical side impact structure must have an absorbed energy equivalent to two baseline steel tubes.
- The perimeter shear strength must be at least 7.5 kN.

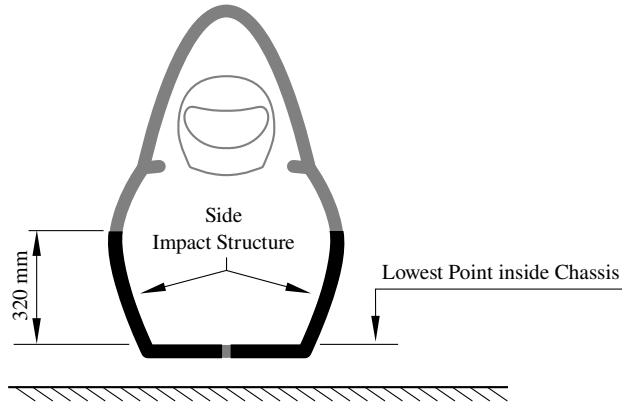

Figure 7: Side impact structure monocoque

T2.17 Bolted Primary Structure Attachments

- T2.17.1 If two parts of the primary structure are bolted together, each attachment point between the two parts must be able to carry a load of 30 kN in any direction.
- T2.17.2 Data obtained from the laminate perimeter shear strength test must be used to prove that adequate shear area is provided.
- T2.17.3 Each attachment point requires a minimum of two 8 mm metric grade 8.8 bolts and steel backing plates with a minimum thickness of 2 mm.
- T2.17.4 For the attachment of front hoop bracing, main hoop bracing and main hoop bracing support to the primary structure the use of one 10 mm metric grade 8.8 bolt is sufficient, if the bolt is on the centerline of the tube (see Figure 8).

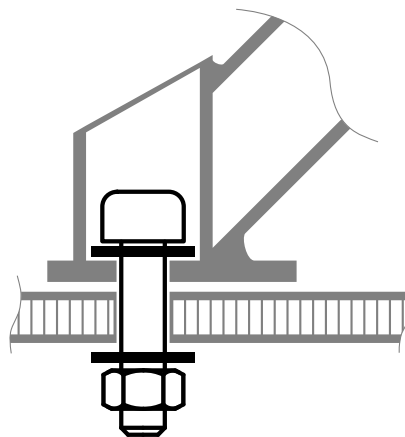

Figure 8: Bolted roll hoop bracing support

T2 General Chassis Design

T2.17.5 When using bolted joints within the primary structure, no crushing of the laminate core material is permitted.

T2.18 Impact Attenuator (IA)

T2.18.1 Each vehicle must be equipped with an IA.

T2.18.2 The IA must be:

- Installed forward of the front bulkhead.
- At least 100 mm high and 200 mm wide for a minimum distance of 200 mm forward of the front bulkhead.
- Not able to penetrate the front bulkhead in the event of an impact.
- Attached securely and directly to the front bulkhead.
- Not part of the non-structural bodywork.
- Designed with a closed front section.

T2.18.3 On all vehicles, a 1.5 mm solid steel or 4.0 mm solid aluminum Anti Intrusion Plate (AIP) must be integrated into the IA.

- If the IA and AIP (IA assembly) are bolted to the front bulkhead, it must be the same size as the outside dimensions of the front bulkhead.
- If it is welded to the front bulkhead, it must extend at least to the centerline of the front bulkhead tubing in all directions.

T2.18.4 Alternative AIP designs are permissible if equivalency to T2.18.3 is proven, either by physical testing as in T2.20.2 or a 3-point bending test and a perimeter shear test as in T2.6. These tests must at least prove that:

- (a) The AIP does not fail under a static bending load of 120 kN distributed evenly over 150 mm of length.
- (b) The perimeter shear strength is sufficient, such that each attachment can withstand a minimum force of 20 kN in any direction.

T2.18.5 If the IA assembly is not integral with the chassis, i.e. welded, a minimum of eight 8 mm metric grade 8.8 bolts must attach the IA assembly to the front bulkhead. The IA may be attached to the AIP by a minimum of four 8 mm metric grade 8.8 bolts.

T2.18.6 The attachment of the IA assembly must be designed to provide an adequate load path for transverse and vertical loads in the event of off-center and off-axis impacts. Segmented foam attenuators must have the segments bonded together to prevent sliding or parallelogramming.

T2.18.7 The attachment of the IA assembly to a monocoque structure requires an approved “Structural Equivalency Spreadsheet” per T2.7 that shows equivalency to a minimum of eight 8 mm metric grade 8.8 bolts.

T2.18.8 If a team uses the “standard” FSAE IA, and the outside edge of the front bulkhead extends beyond the IA assembly by more than 25 mm on any side, a diagonal or X-bracing made from 25 mm × 1.5 mm steel tubing, or an approved equivalent per T2.3, must be included in the front bulkhead.

T2 General Chassis Design

T2.18.9 If the standard IA is used, but does not comply with edge distance limits of T2.18.8 and does not include a diagonal bracing, physical testing must be carried out to prove that the AIP does not permanently deflect more than 25 mm.

T2.19 Impact Attenuator Data Requirement

T2.19.1 All teams must submit an IA data report using the Impact Attenuator Data (IAD) template provided at the competition website.

T2.20 Impact Attenuator Test Requirements

T2.20.1 The IA assembly, when mounted on the front of a vehicle with a total mass of 300 kg and impacting a solid, non-yielding impact barrier with a velocity of impact of 7 m/s, must meet the following requirements:

- Decelerate the vehicle at a rate not exceeding 20 g average and 40 g peak.
- The energy absorbed in this event must meet or exceed 7350 J.
- Teams using the standard IA are not required to submit test data with their IAD report, but all other requirements must be included.

T2.20.2 During the IA test:

- The IA must be attached to the AIP using the intended vehicle attachment method.
- The IA assembly must be attached to a structurally representative section of the intended chassis.
- There must be at least 50 mm clearance rearwards of the AIP to the test fixture.
- No part of the AIP may permanently deflect more than 25 mm beyond the position of the AIP before the test.

T2.20.3 Teams using IAs (typically structural noses) directly attached to the front bulkhead, which shortcut the load path through the bulk of the AIP, must conduct an additional test. This test must prove that the AIP can withstand a load of 120 kN (300 kg multiplied by 40 g), where the load applicator matches the minimum IA dimensions.

T2.20.4 Vehicles with aerodynamic devices and/or environment perception sensors in front of the IA must not exceed the peak deceleration of T2.20.1 for the combination of their IA assembly and the non-crushable object(s). Any of the following three methods may be used to prove the design does not exceed 120 kN:

- (a) Physical testing of the IA assembly including any attached non-crushable object(s) in front of the AIP.
- (b) Combining the peak force from physical testing of the IA assembly with the failure load for the mounting of the non-crushable object(s), calculated from fastener shear and/or link buckling.
- (c) Combining the “standard” IA peak load of 95 kN with the failure load for the mounting of the non-crushable object(s), calculated from fastener shear and/or link buckling.

T3 Cockpit

- T2.20.5 Dynamic testing (sled, pendulum, drop tower, etc) of the IA may only be conducted at a dedicated test facility. This facility may be part of the university, but must be supervised by professional staff. Teams are not allowed to design their own dynamic test apparatus.
- T2.20.6 When using acceleration data from the dynamic test, the average deceleration must be calculated based on the raw unfiltered data. If peaks above the 40 g limit are present in the data, a 100 Hz, 3rd order, low pass Butterworth (−3 dB at 100 Hz) filter may be applied.

T2.21 Non-Crushable Objects

- T2.21.1 All non-crushable objects (e.g. batteries, master cylinders, hydraulic reservoirs) must be rearward of the rear most plane of the front bulkhead and at least 25 mm behind the AIP, except for environment perception sensors, aerodynamic devices and their mountings.

T3 COCKPIT

T3.1 Cockpit Opening

- T3.1.1 The size of the cockpit opening needs to be sufficient for the template shown on the left in Figure 9 to pass vertically from the opening below the top of the side impact structure when held horizontally. The template may be moved fore and aft.
- T3.1.2 If the side impact structure is not made of tubes, the template must pass until it is 320 mm above the lowest inside chassis point between the front and main hoop.
- T3.1.3 The steering wheel, steering column, seat and all padding may be removed for the template to fit. Any other parts may only be removed if they are integrated with the steering wheel.

T3.2 Cockpit Internal Cross Section

- T3.2.1 The cockpit must provide a free internal cross section sufficient for the template shown on the right in Figure 9 to pass from the rear most surface of the front hoop to a point 100 mm rearwards of the face of the rearmost pedal in an inoperative position. The template may be moved up and down. Adjustable pedals must be in their most forward position.
- T3.2.2 The steering wheel and any padding that can be removed without the use of tools while the driver is seated may be removed for the template to fit.
- T3.2.3 The driver's feet and legs must be completely contained within the primary structure when the driver is seated normally and the driver's feet are touching the pedals. In side and front views, any part of the driver's feet or legs must not extend above or outside of this structure.
- T3.2.4 [DV ONLY] To allow for the steering actuator a reduced-height template (reduced by 50 mm, shown in Figure 9) may be used for a section measuring 200 mm horizontally along the template's path (compare T3.2.1).
- T3.2.5 [DV ONLY] The additional space allowed by T3.3.4 (d) and T3.2.4 may only be used for steering, braking and clutch actuators. When the actuators are removed, the standard templates must fit into the cockpit.

T3 Cockpit

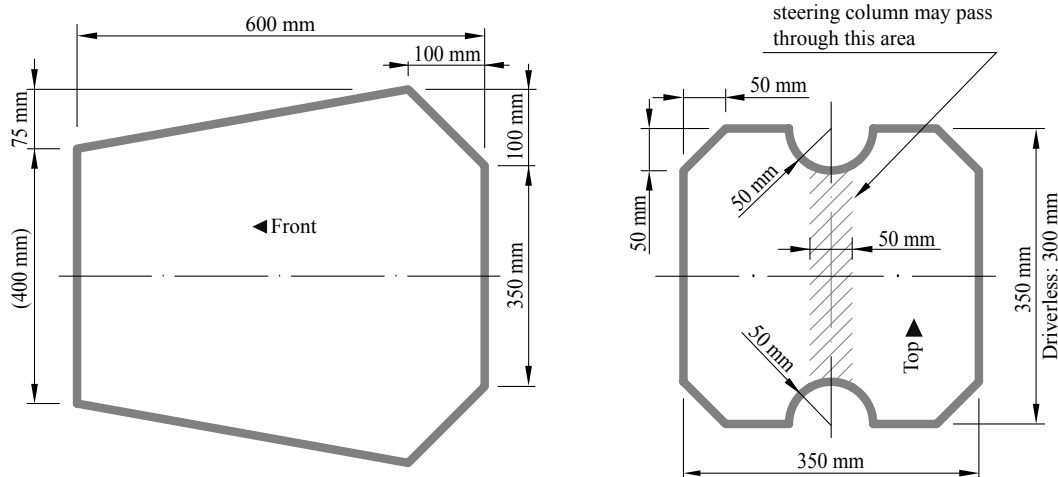

Figure 9: Cockpit opening template (left) and cockpit internal cross section template (right)

T3.3 Percy (95th percentile male)

T3.3.1 When seated normally and restrained by the driver's restraint system, the helmet of a 95th percentile male and all of the team's drivers must (see Figure 10):

- Be a minimum of 50 mm away from the straight line drawn from the top of the main hoop to the top of the front hoop.
- Be a minimum of 50 mm away from the straight line drawn from the top of the main hoop to the lower end of the main hoop bracing if the bracing extends rearwards.
- Be no further rearwards than the rear surface of the main hoop if the main hoop bracing extends forwards.

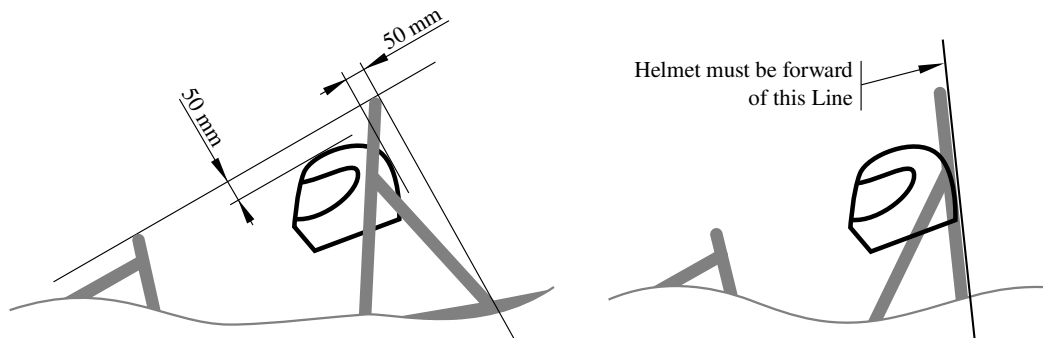

Figure 10: Minimum helmet clearance

T3.3.2 The 95th percentile male is represented by a two dimensional figure consisting of two circles of 200 mm diameter (one representing the hips and buttocks and one representing the shoulder region) and one circle of 300 mm (representing the head with helmet).

T3.3.3 The two 200 mm circles are connected by a straight line measuring 490 mm. The 300 mm circle is connected by a straight line measuring 280 mm with the upper 200 mm circle.

T3.3.4 The figure has to be positioned in the vehicle as follows (see Figure 11):

- The seat adjusted to the rearmost position

T3 Cockpit

- (b) The pedals adjusted to the frontmost position
- (c) The bottom 200 mm circle placed on the seat bottom. The distance between the center of the circle and the rearmost actuation face of the pedals must be minimum 915 mm.
- (d) [DV ONLY] The distance from center of circle and pedals, as mentioned above, may be reduced to 865 mm but only for placement of automated brake, steering or clutch actuators in front of the pedals.
- (e) The middle circle positioned on the seat back
- (f) The upper 300 mm circle positioned 25 mm away from the head restraint.

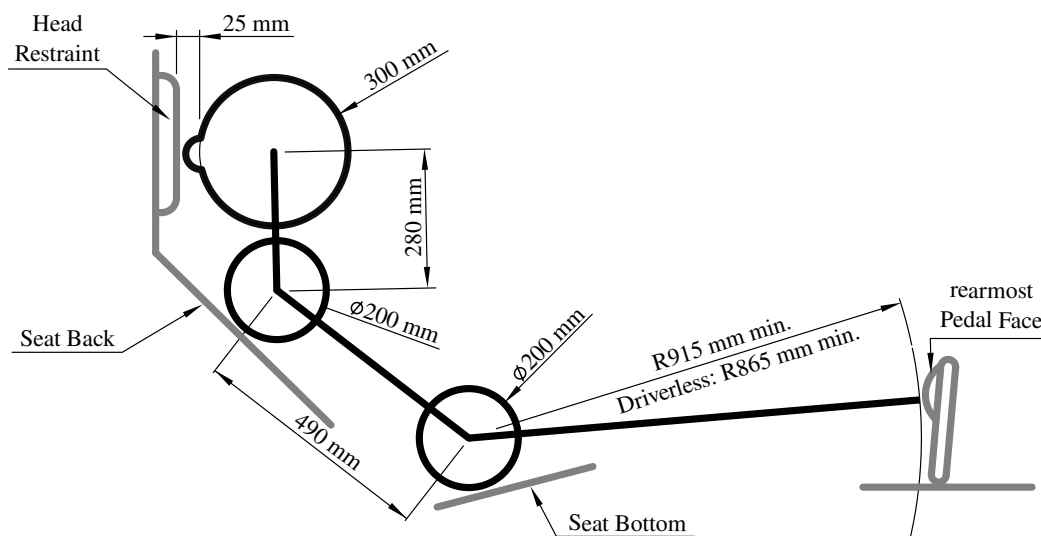

Figure 11: Percy placement

T3.4 Side Tubes

- T3.4.1 If there is any chassis member alongside the driver at the height of the neck of any of the drivers in the team, a metal tube or piece of sheet metal must be attached to the chassis to prevent the driver's shoulders from passing under that chassis member.

T3.5 Driver's Harness Attachment

- T3.5.1 If the attachment of the drivers harness is not welded to a steel structure, it must be proven that the attachments for shoulder and lap belts can support a load of 13 kN and the attachment points of the anti-submarine belts can support a load of 6.5 kN.
- T3.5.2 If the lap belts and anti-submarine belts are attached to the same attachment point, it must support a load of 19.5 kN.
- T3.5.3 The strength of lap belt and shoulder belt attachments must be proven by physical testing where the required load is applied to a representative attachment point with the layup and attachment brackets as in the chassis. The following requirements must be met:
 - (a) Edges of the test fixture supporting the sample must be a minimum of 125 mm from the load application point.

T3 Cockpit

- (b) The width of the shoulder harness test sample must not be any wider than the shoulder harness panel height used to show equivalency for the shoulder harness mounting bar.
- (c) Designs with attachments near a free edge may not support the free edge during the test.
- (d) Harness loads must be tested with the worst case for the range of the angles specified for the driver's harness.

T3.6 Driver's Seat

- T3.6.1 The lowest point of the driver's seat must in side view not extend below the upper face of the lowest side impact structure member or have a longitudinal tube (or tubes) that meets the material requirements for the side impact structure (T2.3), passing underneath the lowest point of the seat.
- T3.6.2 Adequate heat insulation must be provided to ensure that the driver is not able to contact any parts of the vehicle with a surface temperature above 60 °C. The insulation may be external to the cockpit or incorporated with the driver's seat or firewall. The design must address all three types of heat transfer with the following minimum requirements between the heat source and the part that the driver could contact:
- (a) Conduction insulation by:
 - (i) No direct contact, or
 - (ii) a heat resistant, conduction insulation material with a minimum thickness of 8 mm.
 - (b) Convection insulation by a minimum air gap of 25 mm.
 - (c) Radiation insulation by:
 - (i) A solid metal heat shield with a minimum thickness of 0.4 mm or
 - (ii) reflective foil or tape when combined with T3.6.2(a)(ii).

T3.7 Floor Closeout

- T3.7.1 All vehicles must have a floor closeout made of one or more panels, which separate the driver from the ground.
- T3.7.2 The closeout must extend from the front bulkhead to the firewall.
- T3.7.3 The panels must be made of a solid, non-brittle material.
- T3.7.4 If multiple panels are used, gaps between panels may not exceed 3 mm.

T3.8 Firewall

- T3.8.1 A firewall must separate the driver compartment from all components of the fuel supply system, the engine oil, the liquid cooling systems, the low voltage battery and any Tractive System (TS) component (EV 1.1).

T3 Cockpit

- T3.8.2 The firewall must extend sufficiently far upwards and/or rearwards such that any point, less than 100 mm above the bottom of the helmet of the tallest driver, is not in direct line of sight with any of the above mentioned parts.
- T3.8.3 The firewall must be a non-permeable surface made from a rigid, fire resistant material meeting UL94-V0, FAR25 or equivalent, which must be rigidly mounted to the vehicle's structure.
- T3.8.4 Any firewall must seal completely against the passage of fluids, especially at the sides and the floor of the cockpit.
- T3.8.5 Pass-throughs for wiring, cables, etc. are permitted if grommets are used to seal the pass-through.
- T3.8.6 Multiple panels may be used to form the firewall but must be sealed at the joints.
- T3.8.7 [EV ONLY] The tractive system firewall between driver and tractive system components must be composed of two layers:
- (a) One layer, facing the tractive system side, must be made of aluminum with a thickness of at least 0.5 mm. This part of the tractive system firewall must be grounded according to EV 3.1.
 - (b) The second layer, facing the driver, must be made of an electrically insulating material. The material used for the second layer must meet UL94-V0, FAR25 or equivalent. The second layer must not be made of CFRP.
 - (c) The thickness of the second layer must be sufficient to prevent penetrating this layer with a 4 mm wide screwdriver and 250 N of force.
- A sample of the tractive system firewall must be presented at technical inspection.
- T3.8.8 [EV ONLY] Conductive parts (except for the chassis) may not protrude through the firewall or must be properly insulated on the driver's side.
- T3.8.9 [EV ONLY] High Voltage (HV) parts outside of the envelope, see EV 5.4.3, do not need a firewall.

T3.9 Accessibility of Controls

- T3.9.1 All vehicle controls must be operated from inside the cockpit without any part of the driver, e.g. hands, arms or elbows, being outside the vertical planes tangent to the outermost surface of the side impact structure.

T3.10 Driver Visibility

- T3.10.1 The driver must have adequate visibility to the front and sides of the vehicle. Seated in a normal driving position, the driver must have a minimum field of vision of 200° (a minimum 100° to either side). The required visibility may be obtained by the driver turning their head and/or the use of mirrors.
- T3.10.2 If mirrors are required to meet T3.10.1, they must remain in place and be adjusted to enable the required visibility throughout all dynamic events.

T4 Driver Restraint System

T3.11 Driver Egress

T3.11.1 All drivers must be able to exit to the side of the vehicle in less than 5 s with the driver in the fully seated position, hands in the driving position on the connected steering wheel (in all possible steering positions) and wearing the required driver equipment as in T4. The egress time will stop when the driver has both feet on the ground.

T4 DRIVER RESTRAINT SYSTEM

T4.1 Definitions

T4.1.1

- (a) A 6-point system - consists of a two-piece lap belt (minimum width: 75 mm for SFI 16.1, 50 mm for SFI 16.5 or FIA 8853/98), two shoulder straps (minimum width of 75 mm) and two leg or anti-submarine straps (minimum width of 50 mm).
- (b) A 7-point system - system is the same as the 6-point system except it has three anti-submarine straps.
- (c) An “upright driving position” is defined as one with a seat back angled at 30° or less from the vertical as measured along the line joining the two 200 mm circles of the 95th percentile male template as defined in T3.3 and positioned per T3.3.4.
- (d) A “reclined driving position” is defined as one with a seat back angled at more than 30° from the vertical as measured along the line joining the two 200 mm circles of the 95th percentile male template as defined in T3.3 and positioned per T3.3.4.

T4.2 Belts - General

T4.2.1 All drivers must use a 6-point or 7-point restraint harness meeting the following specifications:

- All driver restraint systems must meet SFI Specification 16.1, SFI Specification 16.5 or FIA specification 8853/98.
- The belts must bear the appropriate dated labels.
- The material of all straps must be in perfect condition.
- There must be a single metal-to-metal latch type quick release for all straps.
- All lap belts must incorporate a tilt lock adjuster (“quick adjuster”). A tilt lock adjuster in each portion of the lap belt is highly recommended. Lap belts with “pull-up” adjusters are recommended over “pull-down” adjusters.
- Vehicles with a “reclined driving position” must have either anti-submarine belts with tilt lock adjusters (“quick adjusters”) or have two sets of anti-submarine belts installed.
- The shoulder harness must be the “over-the-shoulder type”. Only separate shoulder straps are permitted (i.e. “Y”-type shoulder straps are not allowed). The “H”-type configuration is allowed.
- It is mandatory that the shoulder harness, where it passes over the shoulders, be 75 mm wide, except with the use of a HANS device. The shoulder harness straps must

T4 Driver Restraint System

be threaded through the three bar adjusters in accordance with the manufacturer's instructions.

- When a HANS device is used by the driver, FIA certified 50 mm wide shoulder harnesses are allowed.

T4.2.2 SFI spec harnesses must be replaced following December 31st of the 2nd year after the date of manufacture as indicated by the label. FIA spec harnesses must be replaced following December 31st of the year marked on the label.

T4.2.3 The restraint system must be worn tightly at all times.

T4.3 Belt, Strap and Harness Installation - General

T4.3.1 The lap belt, shoulder harness and anti-submarine strap(s) must be securely mounted to the primary structure. This structure and any guide or support for the belts must meet the minimum requirements of T2.3.

T4.3.2 The tab or bracket to which any harness is attached must have:

- A minimum cross sectional area of 60 mm² of steel to be sheared or failed in tension at any point of the tab, and
- A minimum thickness of 1.6 mm.
- Where lap belts and anti-submarine belts use the same attachment point, a minimum cross sectional area of 90 mm² of steel to be sheared if failed in tension at any point of the tab.
- Where brackets are fastened to the chassis, two fasteners of 6 mm metric grade 8.8 fasteners or stronger must be used.

T4.3.3 Harnesses, belts and straps must not pass through a firewall, i.e. all harness attachment points must be on the driver's side of any firewall.

T4.3.4 The attachment of the driver's restraint system to a monocoque structure requires an approved SES per T2.7.

T4.4 Lap Belt Mounting

T4.4.1 The lap belt must pass around the pelvic area below the anterior superior iliac spines (the hip bones).

T4.4.2 The lap belts must not be routed over the sides of the seat. The lap belts should come through the seat at the bottom of the sides of the seat to maximize the wrap of the pelvic surface and continue in a straight line to the anchorage point.

T4.4.3 Where the belts or harness pass through a hole in the seat, the seat must be rolled or grommeted to prevent chafing of the belts.

T4.4.4 In side view, the lap belt must be capable of pivoting freely by using either a shouldered bolt or an eye bolt attachment.

T4 Driver Restraint System

- T4.4.5 With an “upright driving position”, in side view the lap belt must be at an angle of between 45° and 65° to the horizontal.
- T4.4.6 With a “reclined driving position”, in side view the lap belt must be between an angle of 60° and 80° to the horizontal.
- T4.4.7 The centerline of the lap belt at the seat bottom should be between 0 mm to 76 mm forward of the seat back to seat bottom junction as in Figure 12.

T4.5 Shoulder Harness

- T4.5.1 The shoulder harness must be mounted behind the driver to a structure that meets the requirements of the primary structure. However, it cannot be mounted to the main hoop bracing or attendant structure without additional bracing to prevent loads being transferred into the main hoop bracing.
- T4.5.2 If the harness is mounted to a tube that is not straight, the joints between this tube and the structure to which it is mounted must be reinforced in side view by triangulation tubes to prevent torsional rotation of the harness mounting tube. Supporting calculations are required. Analysis method: Use 7 kN load per attachment and the range of angles in T4.5.5, calculate that the bent shoulder harness bar triangulation stresses are less than as welded yield strength T2.3.3 for combined bending and shear and does not fail in column buckling. If the team chooses not to perform the strength analysis T2.3.5 will apply.
- T4.5.3 The strength of any shoulder harness bar bracing tubes must be proved in the relevant tab of the team’s SES submission.
- T4.5.4 The shoulder harness mounting points must be between 180 mm and 230 mm apart.
- T4.5.5 From the driver’s shoulders rearwards to the mounting point or structural guide, the shoulder harness must be between 10° above the horizontal and 20° below the horizontal as in Figure 12.

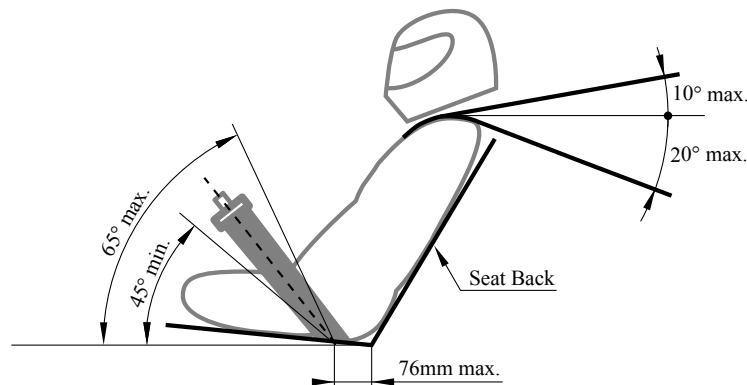

Figure 12: Lap belt and shoulder harness mounting

T4.6 Anti-Submarine Belt Mounting

- T4.6.1 The anti-submarine belts of a 6 point harness should be mounted in one of the following setups:

T4 Driver Restraint System

- With the belts going vertically down from the groin, or angled up to 20° rearwards. The anchorage points should be approximately 100 mm apart.
- With the anchorage points on the primary structure at or near the lap belt anchorages, the driver sitting on the anti-submarine belts and the belts coming up around the groin to the release buckle.

T4.7 Head Restraint

- T4.7.1 A head restraint must be provided on the vehicle to limit the rearward motion of the driver's head.
- T4.7.2 The head restraint must:
- (a) Be vertical or near vertical in side view.
 - (b) Be padded with an energy absorbing material with a minimum thickness of 40 mm that meets either the SFI 45.2 standard, or is listed in the FIA technical list n°17 as a type B material for single seater cars.
 - (c) Have a minimum width and height of 150 mm and have a minimum height adjustment of 175 mm or,
 - (d) have a minimum width of 150 mm and a minimum height of 280 mm.
 - (e) Be located so that for each driver:
 - (i) The restraint is no more than 25 mm away from the back of the driver's helmet, with the driver in their normal driving position.
 - (ii) The contact point of the back of the driver's helmet on the head restraint is no less than 50 mm from any edge of the head restraint.
- T4.7.3 Head restraints must be able to accommodate different drivers.
- T4.7.4 The head restraint, its attachment and its mounting must withstand a force of 890 N applied in the rearward direction at any point on its surface.

T4.8 Roll Bar Padding

- T4.8.1 Any portion of the roll bar, roll bar bracing or chassis which might be contacted by the driver's helmet must be covered with a minimum thickness of 12 mm of padding which meets SFI spec 45.1 or FIA 8857-2001.

T4.9 Driver's Leg Protection

- T4.9.1 All moving suspension and steering components and other sharp edges inside the cockpit between the front hoop and a vertical plane 100 mm rearward of the pedals, must be shielded with solid material.
- T4.9.2 Covers over suspension and steering components must be removable to allow inspection of the mounting points.

T5 Brake System

T5 BRAKE SYSTEM

T5.1 Brake System - General

- T5.1.1 The vehicle must be equipped with a braking system that acts on all four wheels and is operated by a single control.
- T5.1.2 The brake system must have two independent hydraulic circuits such that in the case of a leak or failure at any point in the system, effective braking power is maintained on at least two wheels. Each hydraulic circuit must have its own fluid reserve, either by the use of separate reservoirs or by the use of a dammed reservoir.
- T5.1.3 A single brake acting on a limited-slip differential is acceptable.
- T5.1.4 “Brake-by-wire” systems are prohibited. [DV ONLY] In autonomous mode, it is allowed to use “brake-by-wire”. In manual mode, T5.1.1 applies.
- T5.1.5 Unarmored plastic brake lines are prohibited.
- T5.1.6 The braking systems must be protected from failure of the drivetrain (see T6.4.2) and from minor collisions.
- T5.1.7 In side view any portion of the brake system that is mounted on the sprung part of the vehicle must not project below the lower surface of the chassis.
- T5.1.8 The brake pedal shall be designed to withstand a force of 2 kN without any failure of the brake system or pedal box. This may be tested by pressing the pedal with the maximum force that can be exerted by any official when seated normally.
- T5.1.9 The brake pedal must be fabricated from steel or aluminum or machined from steel, aluminum or titanium.
- T5.1.10 [EV ONLY] The first 90 % of the brake pedal travel may be used to regenerate brake energy without actuating the hydraulic brake system. The remaining brake pedal travel must directly actuate the hydraulic brake system, but brake energy regeneration may remain active.

T5.2 Brake Over-Travel Switch (BOTS)

- T5.2.1 A brake pedal over-travel switch must be installed on the vehicle as part of the shutdown circuit, as in EV 7 or CV 4.1. This switch must be installed so that in the event of a failure in one or both of the brake circuits the brake pedal over travel will result in the shutdown circuit being opened. This must function for all brake pedal and brake balance settings used to drive the vehicle.
- T5.2.2 Repeated actuation of the switch must not close the shutdown circuit, and it must be designed so that the driver cannot reset it.
- T5.2.3 The switch must be implemented with analog components, not incorporating programmable logic controllers, engine control units, or similar functioning digital controllers.
- T5.2.4 The brake over travel switch must be a mechanical single pole, single throw (commonly known as a two-position) switch (push-pull or flip type).

T6 Powertrain

T5.3 Brake Light

T5.3.1 The vehicle must be equipped with one brake light that meets the following requirements:

- A red light with a black background.
- Rectangular, triangular or near round shape.
- Minimum shining surface of 15 cm².
- Clearly visible from the rear in very bright sunlight.
- When LED lights are used without a diffuser, they may not be more than 20 mm apart.
- If a single line of LEDs is used, the minimum length is 150 mm.

T5.3.2 In side view the brake light must be orientated vertical or near vertical and mounted between the wheel centerline and driver's shoulder level. Viewed from the back it should be positioned approximately at the vehicle's centerline.

T6 POWERTRAIN

T6.1 Transmission and Drive

T6.1.1 Any transmission and drivetrain may be used.

T6.1.2 Movement of the vehicle without a person in the vehicle and with the primary master switch in the off position must be possible.

T6.2 Coolant Fluid Limitations

T6.2.1 Water-cooled engines must only use plain water. Electric motors, accumulators or HV electronics may only use plain water or oil as the coolant.

T6.3 System Sealing

T6.3.1 Any cooling or lubrication system must be sealed to prevent leakage.

T6.3.2 Separate catch cans must be employed to retain fluids from any vents for the coolant system or engine lubrication system. Each catch-can must have a minimum volume of 10 % of the fluid being contained or 900 ml whichever is greater.

T6.3.3 Any vent for other systems containing liquid lubricant or coolant must have a catch-can with a minimum volume of 10 % of the fluid being contained or 100 ml, whichever is greater.

T6.3.4 Catch cans must be capable of containing boiling water without deformation. The mountings and hoses must be able to withstand temperatures of at least 100 °C.

T6.3.5 Catch cans must be located rearwards of the firewall below the driver's shoulder level.

T6.3.6 Any catch can on a cooling system must vent through a hose with a minimum internal diameter of 3 mm down to the bottom levels of the chassis.

T7 Aerodynamic Devices

T6.4 Drive Train Shields and Guards

- T6.4.1 The lowest point of any lubrication system can only be lower than the line between the lowest point of the main hoop and the lowest chassis member behind the lubrication system if it is protected from hitting the ground by a structure mounted directly to the chassis.
- T6.4.2 Exposed rotating final drivetrain parts, chains and belts must be fitted with scatter shields. Scatter shields must:
- Cover chains and belts from the drive sprocket to the driven sprocket/chain wheel/belt or pulley.
 - Start and end parallel to the lowest point of the driven sprocket/chain wheel/belt or pulley.
 - Be constructed of non-perforated 2 mm steel or 3 mm aluminum alloy 6061-T6.
- T6.4.3 Scatter shields for high-speed rotating final drivetrain parts (such as electric motors, clutches, sprockets, gears etc.) that have an OEM casing that do not comply with T6.4.2 may be used, if material is added to achieve the minimum required thickness.
- T6.4.4 [EV ONLY] When an electrical motor casing is rotating around the stator or is perforated, a scatter shield must be included around the motor. This scatter shield must be at least 1 mm thick and made from aluminum alloy 6061-T6 or steel.
- T6.4.5 Scatter shields for chains and belts must be centered on the centerline of the chain or belt and remain aligned with the chain or belt under all conditions. The minimum width of the scatter shield should be at least three times the width of the chain or belt. The minimum material requirements are:
- (a) For metallic chains and belts: 2 mm steel.
 - (b) For non-metallic chains and belts: 3 mm aluminum alloy 6061-T6.
- T6.4.6 All fasteners attaching scatter shields and guards must be 6 mm metric grade 8.8 or stronger.
- T6.4.7 Finger guards are required to cover any drivetrain parts that spin while the vehicle is stationary with the engine running. Finger guards may be made of lighter material, sufficient to resist finger forces. Mesh or perforated material may be used but must prevent the passage of a 12 mm diameter object through the guard.

T7 AERODYNAMIC DEVICES

T7.1 Definition Aerodynamic Device

- T7.1.1 A specifically designed structure mounted on the vehicle to guide the airflow around the vehicle, increasing the downforce acting on the vehicle and/or lowering its drag. The mounting of this structure is not regarded as an aerodynamic device, unless it is intentionally designed to be one.

T7.2 Ground Effect Devices

- T7.2.1 Power ground effects are prohibited. No power device may be used to move or remove air from under the vehicle except fans designed exclusively for cooling.

T7 Aerodynamic Devices

T7.3 Restrictions for Aerodynamic Devices

T7.3.1 Height restrictions:

- All aerodynamic devices forward of a vertical plane through the rearmost portion of the front face of the driver head restraint support, excluding any padding, set to its most rearward position, must be lower than 500 mm from the ground.
- All aerodynamic devices in front of the front axle and extending further outboard than the most inboard point of the front tire/wheel must be lower than 250 mm from the ground.
- All aerodynamic devices rearward of a vertical plane through the rearmost portion of the front face of the driver head restraint support, excluding any padding, set to its most rearward position must be lower than 1.2 m from the ground.

T7.3.2 Width restrictions:

- All aerodynamic devices lower than 500 mm from the ground and further rearward than the front axle, must not be wider than a vertical plane touching the outboard face of the front and rear wheel/tire.
- All aerodynamic devices higher than 500 mm from the ground, must not extend outboard of the most inboard point of the rear wheel/tire.

T7.3.3 Length restrictions:

- All aerodynamic devices must not extend further rearward than 250 mm from the rearmost part of the rear tires.
- All aerodynamic devices must not extend further forward than 700 mm from the fronts of the front tires.

T7.3.4 All restrictions must be fulfilled with the wheels pointing straight and with any suspension setup with or without a driver seated in the vehicle.

T7.4 Minimum Edge Radii of Aerodynamic Devices

T7.4.1 All forward facing edges of aerodynamic devices that could contact a pedestrian must have a minimum radius of 5 mm for all horizontal edges and 3 mm for vertical edges.

T7.5 Aerodynamic Devices Stability and Strength

T7.5.1 Any aerodynamic device must be able to withstand a force of 200 N distributed over a minimum surface of 225 cm² and not deflect more than 10 mm in the load carrying direction.

T7.5.2 Any aerodynamic device must be able to withstand a force of 50 N applied in any direction at any point and not deflect more than 25 mm.

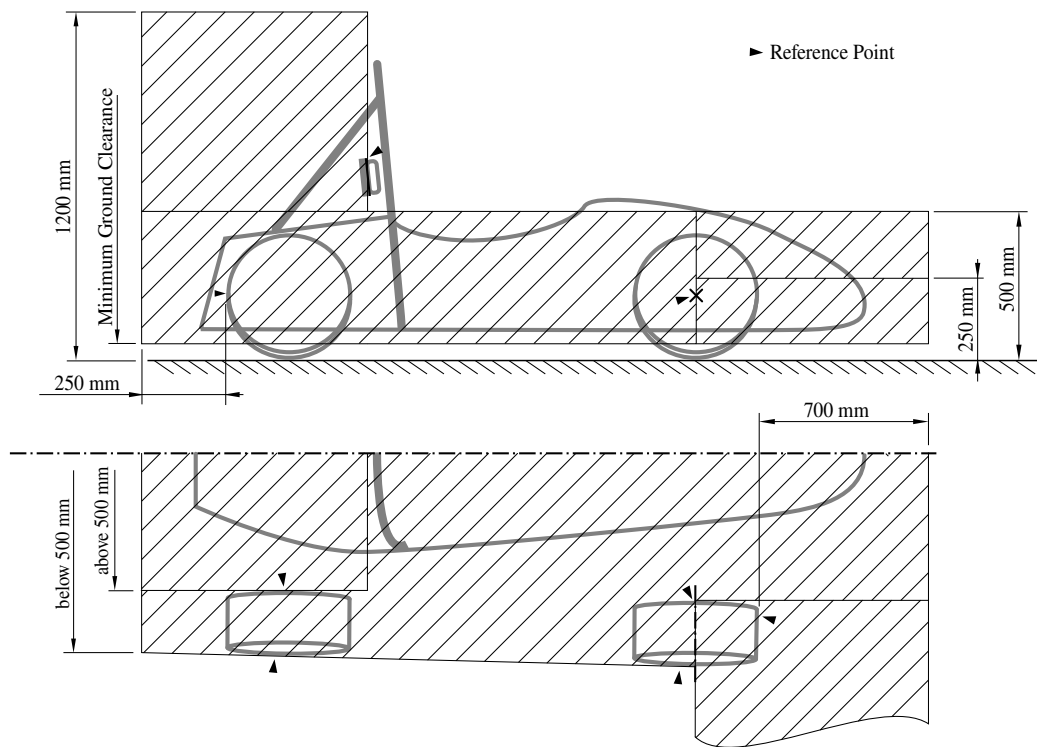

Figure 13: Maximum dimensions and positioning of aerodynamic devices. The positioning space is further restricted (see T 1.1).

T8 COMPRESSED GAS SYSTEMS AND HIGH PRESSURE HYDRAULICS

T8.1 Compressed Gas Cylinders and Lines

T8.1.1 Any system on the vehicle that uses a compressed gas as an actuating medium must comply with the following requirements:

- The working gas must be nonflammable.
- The gas cylinder/tank must be of proprietary manufacture, designed and built for the pressure being used, certified and labeled or stamped appropriately.
- A pressure regulator must be used and mounted directly onto the gas cylinder/tank.
- The gas cylinder/tank and lines must be protected from rollover, collision from any direction, or damage resulting from the failure of rotating equipment.
- The gas cylinder/tank and the pressure regulator must be located within the rollover protection envelope T 2.1.1, but must not be located in the cockpit.
- The gas cylinder/tank must be securely mounted to the chassis, engine or transmission.
- The axis of the gas cylinder/tank must not point at the driver.
- The gas cylinder/tank must be insulated from any heat sources.
- The gas lines and fittings must be appropriate for the maximum possible operating pressure of the system.

T9 Fasteners

T8.2 High Pressure Hydraulic Pumps and Lines

T8.2.1 The driver and anyone standing outside the vehicle must be shielded from any hydraulic pumps and lines with line pressures of 2100 kPa or higher. The shields must be steel or aluminum with a minimum thickness of 1 mm. Brake lines are not considered as high pressure hydraulic lines.

T9 FASTENERS

T9.1 Critical Fasteners

T9.1.1 Critical fasteners are defined as bolts, nuts, and other fasteners utilized in the primary structure, the steering, braking, driver's harness, suspension systems and those specifically designated as critical fasteners in the respective rule.

T9.1.2 All threaded critical fasteners must meet or exceed metric grade 8.8 or equivalent.

T9.1.3 All threaded critical fasteners must be of the type hexagon bolts (DIN 933, DIN 931) or socket head cap screws (DIN 912, DIN 7984) including their fine-pitch thread versions.

T9.1.4 Bolts may be shortened in length as long as T9.2.3 is fulfilled.

T9.1.5 Any bolted joint in the primary structure using either tabs or brackets, must have an edge distance ratio "e/D" of 1.5 or greater. "D" equals the hole diameter and "e" equals the distance from the hole centerline to the nearest free edge of the tab or bracket. Any tabs attaching suspension members to the primary structure are not required to meet this rule.

T9.2 Securing Fasteners

T9.2.1 All critical fasteners must be secured from unintentional loosening by the use of positive locking mechanisms.

T9.2.2 The following methods are accepted as positive locking mechanisms:

- Correctly installed safety wiring.
- Cotter pins.
- Nylon lock nuts (DIN 982, DIN 9626 or equivalent) for low temperature locations (80 °C or less).
- Prevailing torque lock nuts (DIN 980, DIN 6925, ISO 7042 or equivalent, and jet nuts or K-nuts).
- Locking plates.
- Tab washers.

Any locking mechanism based on pre-tensioning or an adhesive is not considered a positive locking mechanism.

T9.2.3 A minimum of two full threads must project from any lock nut.

T10 Electrical Components

- T9.2.4 All spherical rod ends and spherical bearings on the steering or suspension must be in double shear or captured by having a screw/bolt head or washer with an outer diameter that is larger than the spherical bearing housing inner diameter.
- T9.2.5 Adjustable tie-rod ends must be constrained with a jam nut to prevent loosening.

T10 ELECTRICAL COMPONENTS

T10.1 Master Switches

- T10.1.1 Master switches, see CV 4.2, EV 7.2 and DV 2.2, must be a mechanical switch of the rotary type, with a red, removable handle. The handle must have a width of at least 50 mm and must only be removable in electrically open position. They must be direct acting, i.e. they must not act through a relay or logic.
- T10.1.2 Master switches must be located on the right side of the vehicle, in proximity to the main hoop, at the 95th percentile male driver's shoulder height, as defined in T 3.3, and be easily actuated from outside the vehicle.
- Master switches must not be mounted lower than the vertical distance of the template's (T 3.3) middle circle center to the ground surface multiplied by 0.8.
- T10.1.3 The "ON" position of the switch must be in the horizontal position and must be marked accordingly. The "OFF" position of the master switch must also be clearly marked.
- T10.1.4 [EV OR DV ONLY] Master switches must be mounted next to each other.

T10.2 Low Voltage Batteries

- T10.2.1 Low voltage batteries are all batteries except tractive system batteries of electric vehicles.
- T10.2.2 Low voltage batteries must be attached securely to the chassis.
- T10.2.3 Low voltage batteries must be located within the rollover protection envelope, see T2.1.1.
- T10.2.4 Any wet-cell battery located in the driver compartment must be enclosed in a non-conductive, water proof (according to IPX7 or higher, IEC 60529) and acid resistant container.
- T10.2.5 Low voltage batteries must have a rigid and sturdy casing.
- T10.2.6 The hot (ungrounded) terminal must be insulated.
- T10.2.7 Low voltage batteries must be protected for short circuits.
- T10.2.8 Battery packs based on lithium chemistry other than lithium iron phosphate (LiFePO₄):
- (a) Must include overcurrent protection that trips at or below the maximum specified discharge current of the cells.
 - (b) Must have a fire resistant casing according to UL94-V0, FAR25 or equivalent.
 - (c) Must include overtemperature protection of at least 30 % of the cells that trips at or below the maximum specified temperature of the cells or at 60 °C, whichever is lower and disconnects the battery.

T 10 Electrical Components

- (d) Must include voltage protection of all cells that trips when any cell leaves the allowed voltage range on the manufacture's datasheet and disconnects the battery.
- (e) It must be possible to display all cell voltages and measured temperatures, e.g. by connecting a laptop.
- (f) Signals needed to fulfil this requirements are System Critical Signal (SCS), see T 10.4.

T 10.3 Accelerator Pedal Position Sensor (APPS)

- T 10.3.1 T 10.3 only apply for electric vehicles, see chapter EV, or internal combustion vehicles using Electronic Throttle Control (ETC), see CV 1.6.
- T 10.3.2 The APPS must be actuated by a foot pedal.
- T 10.3.3 Pedal travel is defined as percentage of travel from fully released position to a fully applied position where 0 % is fully released and 100 % is fully applied.
- T 10.3.4 The foot pedal must return to the 0 % position when not actuated. The foot pedal must have a positive stop preventing the mounted sensors from being damaged or overstressed. Two springs must be used to return the foot pedal to the 0 % position and each spring must work when the other is disconnected. Springs in the APPS are not accepted as return springs.
- T 10.3.5 At least two separate sensors must be used as APPSs. Separate is defined as not sharing supply or signal lines.
- T 10.3.6 If analog sensors are used, they must have different transfer functions, each having a positive slope sense with either different gradients and/or offsets to the other(s). This will insure that even in case of a short circuit of the signal lines the APPSs will only agree at 0 % pedal position.
- T 10.3.7 The APPS signal is a System Critical Signal, see T 10.4.
- T 10.3.8 If an implausibility occurs between the values of the APPSs and persists for more than 100 ms
 - [EV ONLY] The power to the motor(s) must be immediately shut down completely. It is not necessary to completely deactivate the tractive system, the motor controller(s) shutting down the power to the motor(s) is sufficient.
 - [CV ONLY] The power to the electronic throttle must be immediately shut down.
- T 10.3.9 Implausibility is defined as a deviation of more than ten percentage points pedal travel between any of the used APPSs or any failure according to T 10.4.
- T 10.3.10 If three sensors are used, then in the case of an APPS implausibility, any two sensors that are plausible may be used to define the torque target and the 3rd APPS may be ignored.
- T 10.3.11 Each APPS must have a separate detachable connector that enables a check of these functions by unplugging it. If not, an inline switchable break-out box must be made available during technical inspection that allows disconnection of each APPS signal.
- T 10.3.12 A fully released accelerator pedal must result in:
 - [EV ONLY] A wheel torque of ≤ 0 Nm

T10 Electrical Components

- [CV ONLY] An idle position or lower throttle set-point. This may only be exceeded during a gearshift for a maximum of 500 ms.

T10.4 System Critical Signals (SCSs)

T10.4.1 SCS are defined as all electrical signals which

- Influence actions on the shutdown circuit, see CV4.1 and EV7.1.
- Influence the requested wheel torque.
- [EV ONLY] Influence indicators according to EV 6.8.8, EV 5.10 or EV 7.4.5.
- [DV ONLY] Influence indicator according to DV 3.2.6.

T10.4.2 Any of the following SCS failures must result in a safe state of all connected systems:

(a) Failures of signals transmitted by cable:

- Open circuit
- Short circuit to ground

(b) Failures of analog sensor signals transmitted by cable:

- Short circuit to supply voltage

(c) Failures of sensor signals used in programmable logic:

- Implausibility due to out of range signals, e.g. mechanically impossible angle of an angle sensor.

(d) Failures of digitally transmitted signals by cable or wireless:

- Data corruption (e.g. checked by a checksum)
- Loss and delay of messages (e.g. checked by transmission time outs)

Signals might be a member of multiple signal classes, e.g. analog signals transmitted by cable might be a member of (a), (b) and (c).

If a signal failure is correctable, e.g. due to redundancy, the safe state must be entered as soon as an additional non correctable failure occurs.

T10.4.3 Safe state is defined as follows:

- Indicators – Indicating a failure of its own function or of the connected system
- Low Voltage Battery – Electrically disconnected from the rest of the vehicle
- [EV ONLY] others – opened shutdown circuit and opened AIRs
- [CV ONLY] others – opened shutdown circuit and stopped engine

T10.4.4 Indicators according to T10.4.1 with safe state “illuminated” (e.g. absence of failures is not actively indicated) must be illuminated for 1 s to 3 s for visible check after power cycling the GLVMS.

T11 Vehicle Identification

T10.5 Inertia Switch

- T10.5.1 All vehicles must be equipped with an inertia switch. This must be a “Sensata Resettable Crash Sensor” or equivalent.
- T10.5.2 The inertia switch must be part of the shutdown circuit (see CV 4.1 and EV 7.1), such that an impact will result in the shutdown circuit being opened. The inertia switch must latch until manually reset.
- T10.5.3 The device must trigger due to an impact load which decelerates the vehicle at between 6 g and 11 g depending on the duration of the deceleration (see specification of the Sensata device).
- T10.5.4 The device must be rigidly attached to the vehicle; however, it must be possible to demount the device so that its functionality may be tested by shaking it.

T11 VEHICLE IDENTIFICATION

T11.1 Vehicle Number

- T11.1.1 Each vehicle will be assigned a number at the time of its entry into a competition.
- T11.1.2 Vehicle numbers must appear on the vehicle at the front and both sides as follows:
- Height: At least 150 mm high;
 - Font: Roman Sans-Serif characters. Italic, outline, serif, or shadow numbers are prohibited.
 - Stroke width and spacing between numbers: At least 20 mm.
 - Color: Either white numbers on a black background or black numbers on a white background.
 - Background shape: The number background must be one of the following: round, oval, square or rectangular. There must be at least 25 mm between the edge of the numbers and the edge of the background.
 - Clear: The numbers must not be obscured by parts of the vehicle.

T11.2 University Name

- T11.2.1 The university name must be written fully. Only the following abbreviations in the university name are accepted if the city name is written fully:
- (a) University → Uni
 - (b) Technical University → TU
 - (c) University of Applied Sciences → UAS
 - (d) Berufsakademie → BA.
 - (e) If the university officially uses an abbreviation in their proper name, this abbreviation is accepted.

T12 Vehicle and Driver Equipment

T11.2.2 The university name must be displayed and written in Roman Sans-Serif characters of at least 50 mm high on both sides of the vehicle.

T11.2.3 The characters must be clearly visible at a distance and placed on a high contrast background.

T11.3 Timing Equipment

T11.3.1 All vehicles will get timing equipment provided by the competition organizers.

T 12 VEHICLE AND DRIVER EQUIPMENT

T 12.1 Pushbar

T 12.1.1 Each team must have a removable device (called the pushbar) that attaches to the rear of the vehicle and allows two people to push and pull the vehicle while standing erect behind the vehicle.

T 12.1.2 The pushbar must have a red color.

T 12.1.3 The pushbar must be presented during technical inspection.

T 12.1.4 The pushbar must be capable of slowing and stopping the forward motion of the vehicle and pulling it rearwards.

T 12.1.5 An approved fire extinguisher (see T 12.4.1) must be mounted to the pushbar such that it is quickly accessible.

T 12.1.6 [EV ONLY] Two pairs of high-voltage insulating gloves and a multimeter must be attached to the pushbar. The HV gloves must be protected by a case or similar means from mechanical damage, humidity and sunlight. It must be possible to open the case without using tools.

T 12.2 Quick Jack

T 12.2.1 Each team must have a removable device (called the quick jack) that lifts up the vehicle, so that all driven wheels are at least 100 mm off the ground and the vehicle is adequately supported.

T 12.2.2 The lifting of the vehicle with the quick jack must be possible by one person and not require actions other than positioning and operating the quick jack itself.

T 12.2.3 In the lifted position the quick jack must be locked and secured, and function without the support of a person or additional weights.

T 12.2.4 The quick jack must have a red color.

T 12.2.5 The quick jack must be presented during technical inspection.

T 12.3 Driver Equipment

T12 Vehicle and Driver Equipment

- T 12.3.1 The equipment specified below must be worn by the driver anytime while in the cockpit with the engine running or with the tractive system active for electric vehicles and anytime between starting a dynamic event and either finishing or abandoning a dynamic event. Removal of any driver equipment during the event will result in disqualification.
- T 12.3.2 A well-fitting, closed face helmet that meets one of the following certifications and is labeled as such:
- Snell K2005, K2010, K2015, M2005, M2010, M2015, SA2005, SA2010, SAH2010, SA2015, EA2016
 - SFI 31.1/2005, 31.1/2010, 31.1/2015, 41.1/2005, 41.1/2010, 41.1/2015
 - FIA 8860-2004, FIA 8858-2010, FIA 8860-2010, FIA 8859-2015
 - British Standards Institution BS 6658-85 Type A/FR rating (Types A and B are not accepted)
- Open faced helmets and off-road helmets (helmets without integrated eye shields) are not approved. All helmets to be used in the competition must be presented during technical inspection where approved helmets will be stickered. The officials reserve the right to impound all non-approved helmets until the end of the competition.
- T 12.3.3 A balaclava which covers the driver's head, hair and neck, made from acceptable fire resistant material as defined in T 12.3.11, or a full helmet skirt of acceptable fire resistant material.
- T 12.3.4 A fire resistant one piece suit, made from a minimum of two layers that covers the body from the neck down to the ankles and the wrists. The suit must be certified to one of the following standards and be labeled as such:
- SFI 3-2A/5 (or higher)
 - FIA Standard 1986
 - FIA Standard 8856-2000
- T 12.3.5 Fire resistant underwear (long pants and long sleeve t-shirt). This fire resistant underwear must be made from acceptable fire resistant material as listed in T 12.3.11 and must cover the driver's body completely from neck down to ankles and wrists.
- T 12.3.6 Fire resistant socks made from acceptable fire resistant material as defined in T 12.3.11, that cover the bare skin between the driver's suit and the boots or shoes.
- T 12.3.7 Fire resistant shoes made from acceptable fire resistant material as defined in T 12.3.11. The shoes must be certified to the standard and labeled as such:
- SFI 3.3
 - FIA 8856-2000
- T 12.3.8 Fire resistant gloves made from made from acceptable fire resistant material as defined in T 12.3.11. Gloves of all leather construction or fire resistant gloves constructed using leather palms with no insulating fire resisting material underneath are not acceptable.
- T 12.3.9 Arm restraints are required and must be worn such that the driver can release them and exit the vehicle unassisted regardless of the vehicle's position. Arm restraints must be commercially manufactured according to SFI Standard 3.3 or equivalent.

T 12 Vehicle and Driver Equipment

- T 12.3.10 All driver equipment covered in T 12.3: must be in good condition. Specifically, it must not have any tears, rips, open seams, areas of significant wear or abrasion or stains which might compromise fire resistant performance.
- T 12.3.11 For the purpose of this section some, but not all, of the approved fire resistant materials are: Carbon X, Indura, Nomex, Polybenzimidazole (commonly known as PBI) and Proban.
- T 12.3.12 T-shirts, socks or other undergarments made from nylon or any other synthetic material which will melt when exposed to high heat are prohibited.

T 12.4 Fire Extinguishers

- T 12.4.1 Each team must have at least two dry chemical/dry powder fire extinguishers with a minimum firefighting agent capacity of 0.9 kg.
- T 12.4.2 The following are the minimum accepted ratings:
- USA, Canada and Brazil: 10BC or 1A 10BC
 - Europe: 34B or 5A 34B
 - Australia: 20BE or 1A 10BE
- Extinguishers of larger capacity (higher numerical ratings) are acceptable.
- T 12.4.3 Aqueous Film Forming Foam (AFFF) fire extinguishers are prohibited. Halon extinguishers and systems are prohibited.
- T 12.4.4 All extinguishers must be equipped with a manufacturer installed pressure/charge gauge.
- T 12.4.5 Except for the initial inspection, one extinguisher must readily be available in the team's paddock area, and the second must accompany the vehicle wherever the vehicle is moved. Both extinguishers must be presented with the vehicle at technical inspection.
- T 12.4.6 Hand held fire extinguishers are not permitted to be mounted on or in the vehicle.

T 12.5 Camera Mounts

- T 12.5.1 The mounts for video/photographic cameras must be of a safe and secure design:
- All camera installations must be approved at technical inspection.
 - Helmet mounted cameras are prohibited.
 - The body of any camera or recording unit must be secured at a minimum of two points on different sides of the camera body. If a tether is used to restrain the camera, the tether length must be limited so that the camera cannot contact the driver.
- [DV ONLY] Cameras used as input sensors for driverless vehicles are exempted and have to follow DV 4 instead.

CV INTERNAL COMBUSTION ENGINE VEHICLES

CV1 INTERNAL COMBUSTION ENGINE POWERTRAINS

CV1.1 Engine Limitation

CV 1.1.1 The engine(s) used to power the vehicle must be piston engine(s) using a four-stroke primary heat cycle with a displacement not exceeding 710 cm³ per cycle. All waste/rejected heat from the primary heat cycle may be used. The method of conversion is not limited to the four-stroke cycle. Hybrid powertrains, such as those using electric motors running off stored energy, are prohibited.

CV1.2 Starter

CV 1.2.1 Each vehicle must be equipped with an on-board starter, which must be used to start the vehicle.

CV 1.2.2 [DV ONLY] The vehicle must be equipped with an additional engine start button next to the master switch (see CV 4.2), that can be easily actuated from outside the vehicle. Using the external engine start button, the engine may only start if

- (a) the ASMS (see DV 2.2) is switched on and
- (b) the gearbox is in neutral.

CV 1.2.3 [DV ONLY] There must be a green light next to the engine start button, that indicates that the gearbox is in neutral. It must be marked with the letter "N". This letter must have a minimum height of 25 mm.

CV 1.2.4 [DV ONLY] The autonomous system must not be able to (re-)start the engine.

CV1.3 Air Intake System

CV 1.3.1 All parts of the engine air and fuel control systems (including the throttle and the complete air intake system, including the air filter and any air boxes) must lie within the surface defined by the top of the roll bar and the outside edge of the four tires. (See Figure 14).

CV 1.3.2 Any portion of the air intake system that is less than 350 mm above the ground must be shielded from side or rear impact collisions by structure built to T2.16.

CV 1.3.3 The intake manifold must be securely attached to the engine block or cylinder head with brackets and mechanical fasteners. The threaded fasteners used to secure the intake manifold are considered critical fasteners and must comply with T9.

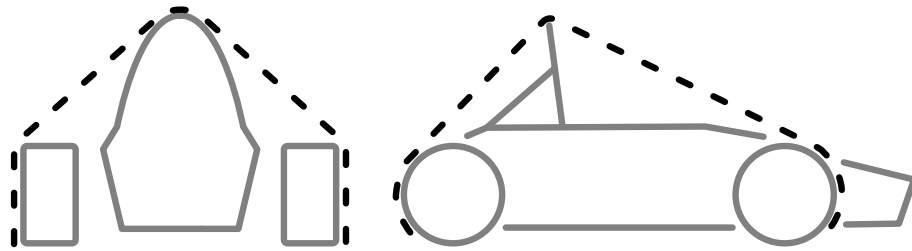

Figure 14: Air intake and fuel systems envelope

CV 1.3.4 Intake systems with significant mass or cantilever from the cylinder head must be supported to prevent stress to the intake system. Supports to the engine must be rigid. Supports to the chassis must incorporate isolation to allow for engine movement and chassis torsion.

CV 1.4 Throttle

CV 1.4.1 The vehicle must be equipped with a throttle body. The throttle body may be of any size or design.

CV 1.4.2 The throttle must be actuated mechanically by a foot pedal, i.e. via a cable or a rod system, see CV 1.5, or by an ETC system, see CV 1.6.

CV 1.4.3 Throttle position is defined as percentage of travel from fully closed to fully open where 0 % is fully closed and 100 % is fully open. The idle position is the average position of the throttle body while the engine is idling.

CV 1.4.4 The throttle system mechanism must be protected from debris ingress to prevent jamming.

CV 1.5 Mechanical Throttle Actuation

CV 1.5.1 CV 1.5 only applies if no ETC system is used.

CV 1.5.2 The throttle actuation system must use at least two return springs located at the throttle body, so that the failure of any one of the two springs will not prevent the throttle returning to the idle position.

CV 1.5.3 Each return spring must be capable of returning the throttle to the idle position with the other disconnected.

CV 1.5.4 Springs in the Throttle Position Sensor (TPS) are not acceptable as return springs.

CV 1.5.5 Throttle cables must be located at least 50 mm from any exhaust system component and out of the exhaust stream.

CV 1.5.6 Throttle cables or rods must have smooth operation and must not have the possibility of binding or sticking. They must be protected from being bent or kinked by the driver's foot during operation or when entering the vehicle.

CV 1.5.7 A positive pedal stop must be incorporated on the accelerator pedal to prevent over-stressing the throttle cable or actuation system.

CV1 Internal Combustion Engine Powertrains

CV1.6 Electronic Throttle Control (ETC)

CV 1.6.1 CV 1.6 only applies if ETC is used.

CV 1.6.2 [DV ONLY] Any DV with internal combustion engine is assumed to have ETC.

CV 1.6.3 An ETC system that is commercially available, but does not comply with CV 1.6, may be used, only if it does comply with the intent of the rules and is approved by the officials. To obtain approval, the team must:

- Submit an additional page in the system description with intent of using such a system.
- Include the specific ETC rule(s) that the commercial system deviates from.
- Include sufficient technical details of these deviations to allow the acceptability of the commercial system to be determined.

CV 1.6.4 The team must be able to demonstrate the functionality of all safety features and error detections of the ETC system at technical inspection, see IN.

CV 1.6.5 The ETC system must be equipped with at least the following sensors:

- Accelerator Pedal Position Sensor (APPS) as defined in T 10.3
- Two Throttle Position Sensor (TPS) to measure the throttle position.
- One Brake System Encoder (BSE) to measure brake pedal position or brake system pressure to check for plausibility.
[DV ONLY] BSE must be pressure type.

CV 1.6.6 All ETC signals are System Critical Signals (SCSs), see T 10.4.

CV 1.6.7 When power is removed, the electronic throttle must immediately close at least to idle position $\pm 5\%$. An interval of one second is allowed for the throttle to close to idle, failure to achieve this within the required interval must result in immediate disabling of power to ignition, fuel injectors and fuel pump. This action must remain active until the TPS signals indicate the throttle has returned to the requested position for at least one second.

CV 1.6.8 If plausibility does not occur between the values of at least two TPSs and this persists for more than 100 ms, the power to the electronic throttle must be immediately shut down. Plausibility is defined as a deviation of less than ten percentage points between the sensor values as defined in CV 1.4.3 and no detected failures as defined in T 10.4.

[DV ONLY] Autonomous system must check this signal consistency on a low level itself.

CV 1.6.9 The electronic throttle must use at least two sources of energy capable of returning the throttle to the closed position. One of the sources may be the device that normally actuates the throttle, e.g. a DC motor, but the other device(s) must be a return spring that can return the throttle to the idle position in the event of a loss of actuator power.

CV 1.6.10 Springs in the TPSs are not acceptable as return springs.

CV 1.6.11 The power to the electronic throttle must be immediately shut down, as defined in CV 1.6.7, if the throttle position differs by more than 10% from the expected target TPS position for more than one second.

CV1 Internal Combustion Engine Powertrains

- CV 1.6.12 Teams must submit a detailed description of their ETC system not later than the deadline specified in the competition handbook. The document must follow the template layout which is available on the competition website.
- CV 1.6.13 A standalone non-programmable circuit must be used on the vehicle such that when braking hard (for example >0.8 g deceleration but without locking the wheels) and when the TPS shows that the throttle is more than five percentage points over idle position, the power to the electronic throttle must be shut down and the shutdown circuit, see CV 4.1, must be opened. The action must occur if the implausibility is persistent for more than one second. This device must be provided in addition to the plausibility checks which are carried out in the Electronic Control Unit (ECU) which interprets the drivers throttle request and controls the engine throttle position. The Brake System Plausibility Device (BSPD) may only be reset by power cycling the master switch (CV 4.2). All BSPD signals are System Critical Signal, see T 10.4.

CV1.7 Intake System Restrictor

- CV 1.7.1 If more than one engine is used, the air for all engines must pass through a single air intake restrictor.
- CV 1.7.2 In order to limit the power capability from the engine, a single circular restrictor must be placed in the intake system and all engine airflow must pass through the restrictor. The only allowed sequence of components are the following:
- For naturally aspirated engines, the sequence must be: throttle body, restrictor, and engine. (See Figure 15)
 - For turbocharged or supercharged engines, the sequence must be: restrictor, compressor, throttle body, engine. (See Figure 16)
- CV 1.7.3 The maximum restrictor diameters which must be respected at all times during the competition are:
- Gasoline fueled vehicles - 20 mm
 - E-85 fueled vehicles - 19 mm
- CV 1.7.4 The restrictor must be located to facilitate measurement during the inspection process.
- CV 1.7.5 The circular restricting cross section may not be movable or flexible in any way, e.g. the restrictor must not be part of the movable portion of a barrel throttle body.

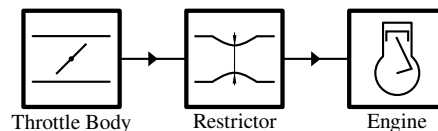

Figure 15: Intake configuration for naturally aspirated engines.

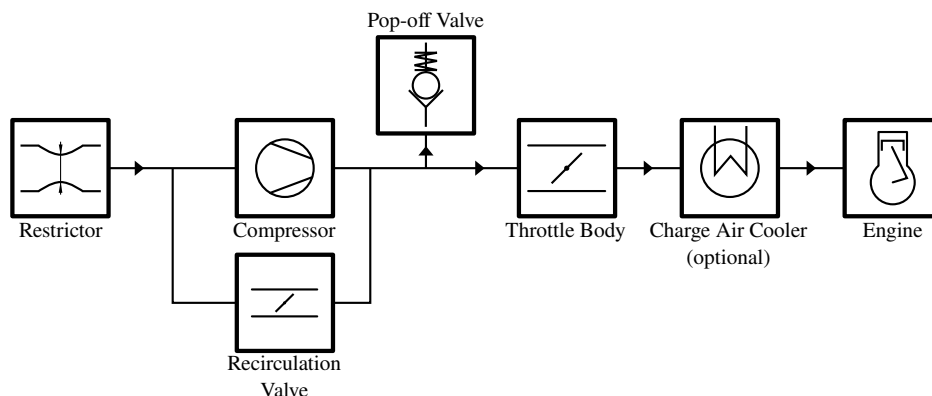

Figure 16: Intake configuration for turbocharged or supercharged engines.

CV1.8 Turbochargers and Superchargers

- CV 1.8.1 The intake air may be cooled with an intercooler. Only ambient air may be used to remove heat from the intercooler system. Air-to-air and water-to air intercoolers are permitted. The coolant of a water-to-air intercooler system must be plain water without any additives.
- CV 1.8.2 If pop-off valves, recirculation valves, or heat exchangers (intercoolers) are used, they may only be positioned in the intake system as shown in Figure 16.
- CV 1.8.3 Plenums anywhere upstream of the throttle body are prohibited. A “plenum” is any tank or volume that is a significant enlargement of the normal intake runner system.
- CV 1.8.4 The maximum allowable internal diameter of the intake runner system between the restrictor and throttle body is 60 mm diameter, or the equivalent area of 2827 mm² if non-circular.

CV1.9 Crankcase / Engine Lubrication Venting

- CV 1.9.1 Any crankcase or engine lubrication vent lines routed to the intake system must be connected upstream of the intake system restrictor.
- CV 1.9.2 Crankcase breathers that pass through the oil catch tank(s) to exhaust systems, or vacuum devices that connect directly to the exhaust system, are prohibited.

CV 2 FUEL AND FUEL SYSTEM

CV2.1 Fuel

- CV 2.1.1 The available fuel types will be unleaded gasoline 98RON and E85.
- CV 2.1.2 The vehicles must be operated with the fuels provided at the competition.
- CV 2.1.3 No agents other than fuel (gasoline or E85), and air may be induced into the combustion chamber.
- CV 2.1.4 The temperature of fuel introduced into the fuel system may not be changed with the intent to improve calculated efficiency.

CV2 Fuel and Fuel System

CV2.2 Fuel System Location Requirements

- CV 2.2.1 All parts of the fuel storage and supply system must lie within the surface defined by the top of the roll bar and the outside edge of the four tires (see Figure 14). In side view no portion of the fuel system can project below the lower surface of the chassis.
- CV 2.2.2 All fuel tanks must be shielded from side or rear impact collisions. Any fuel tank which is located outside the side impact structure required by T2.16 must be shielded by a structure built to T2.16. Any portion of the fuel system that is less than 350 mm above the ground must be within the primary structure.
- CV 2.2.3 All parts of the fuel storage and supply system must be adequately protected against any heat sources and located at least 50 mm from any exhaust system component.

CV2.3 Fuel Tanks

- CV 2.3.1 The fuel tank is defined as the part of the fuel containment device that is in contact with the fuel. It may be made of a rigid material or a flexible material.
- CV 2.3.2 Fuel tanks made of a rigid material cannot be used to carry structural loads and must be securely attached to the vehicle structure with mountings that allow some flexibility such that chassis flex cannot unintentionally load the fuel tank.
- CV 2.3.3 Any fuel tank that is made from a flexible material, for example a bladder fuel cell or a bag tank, must be enclosed within a rigid fuel tank container which is securely attached to the vehicle structure. Fuel tank containers (containing a bladder fuel cell or bag tank) may be load carrying.
- CV 2.3.4 The fuel system must have a provision for emptying the fuel tank if required.
- CV 2.3.5 The fuel tank, by design, must not have a variable capacity.

CV2.4 Fuel Lines for Low Pressure Systems

- CV 2.4.1 Fuel lines between fuel tank and fuel rail and return lines must have:
- Reinforced rubber fuel lines or hoses with an abrasive protection with a fuel hose clamp which has a full 360° wrap, a nut and bolt system for tightening and rolled edges to prevent the clamp cutting into the hose, or
 - Metal braided hoses with crimped-on or reusable, threaded fittings.
- CV 2.4.2 Fuel lines must be securely attached to the vehicle and/or engine.
- CV 2.4.3 All fuel lines must be shielded from possible rotating equipment failure or collision damage.

CV2.5 Fuel Injection System Requirements

Low Pressure Injection (LPI) fuel systems are those functioning at a pressure below 10 bar and High Pressure Injection (HPI) fuel systems are those functioning at 10 bar pressure or above. Direct Injection (DI) fuel systems are those where the injection occurs directly into the combustion chamber.

CV2 Fuel and Fuel System

CV2.5.1 The following requirements apply to LPI fuel systems:

- The fuel lines must comply with CV2.4.
- The fuel rail must be securely attached to the engine cylinder block, cylinder head, or intake manifold with mechanical fasteners. The threaded fasteners used to secure the fuel rail are considered critical fasteners and must comply with T9.
- The use of fuel rails made from plastic, carbon fiber or rapid prototyping flammable materials is prohibited. However, the use of unmodified Original Equipment Manufacturer (OEM) Fuel Rails manufactured from these materials is acceptable.

CV2.5.2 The following requirements apply to HPI and DI fuel systems:

- All high pressure fuel lines must be stainless steel rigid line or Aeroquip FC807 smooth bore PTFE hose with stainless steel reinforcement and visible Nomex tracer yarn. Use of elastomeric seals is prohibited. Lines must be rigidly connected every 100 mm by mechanical fasteners to structural engine components.
- The fuel rail must be securely attached to the engine cylinder head with mechanical fasteners. The fastening method must be sufficient to hold the fuel rail in place with the maximum regulated pressure acting on the injector internals and neglecting any assistance from in-cylinder pressure acting on the injector tip. The threaded fasteners used to secure the fuel rail are considered critical fasteners and must comply with T9.
- The fuel pump must be rigidly mounted to structural engine components.
- A fuel pressure regulator must be fitted between the high and low pressure sides of the fuel system in parallel with the DI boost pump. The external regulator must be used even if the DI boost pump comes equipped with an internal regulator.
- Prior to the tilt test specified in IN 7, engines fitted with mechanically actuated fuel pumps must be run to fill and pressure the system downstream of the high pressure pump.

CV2.6 Fuel Tank Filler Neck and Sight Tube

CV2.6.1 All fuel tanks must have a filler neck which is:

- At least 35 mm diameter at any point between the fuel tank and the top of the fuel filler cap.
- At least 125 mm vertical height above the top level of the tank.
- Angled at no more than thirty degrees (30°) from the vertical and
- accompanied by a clear fuel resistant sight tube with a length of at least 125 mm vertical height for reading the fuel level (see Figure 17).
- Made of material that is rated for temperatures of at least 130 °C.

CV2.6.2 A clear filler neck tube may be used as a sight tube.

CV2.6.3 A permanent, non-moveable, clear and easily visible fuel level line must be located between 12 mm and 25 mm below the top of the visible portion of the sight tube. This line will be used as the fill line for the tilt test (IN 7.2), and before and after the endurance test to measure the amount of fuel used during the endurance event.

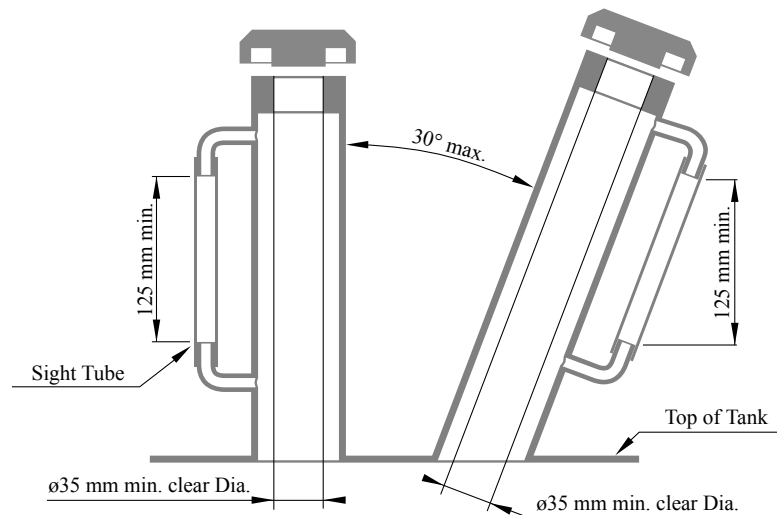

Figure 17: Minimum requirements fuel tank filler neck.

CV 2.6.4 The filler neck opening must be directly accessible without removing any parts of the vehicle except for the fuel filler cap.

CV 2.6.5 The filler neck must have a fuel filler cap that can withstand severe vibrations or high pressures such as could occur during a vehicle rollover event.

CV 2.7 Tank Filling Requirement

CV 2.7.1 The fuel tank must be capable of being filled to capacity without manipulating the tank or the vehicle in any manner. The fuel system must be designed in a way that during refueling of the vehicle on a level surface, the formation of air cavities or other effects that cause the fuel level observed at the sight tube to drop after movement or operation of the vehicle (other than due to consumption) is prevented.

CV 2.7.2 The fuel system must be designed such that the spillage during refueling cannot contact the driver position, exhaust system, hot engine parts, or the ignition system.

CV 2.8 Venting Systems

CV 2.8.1 The fuel tank venting systems must be designed such that fuel cannot spill during hard cornering or acceleration.

CV 2.8.2 All fuel vent lines must be equipped with a check valve to prevent fuel leakage when the tank is inverted. All fuel vent lines must exit outside the bodywork.

CV 3 EXHAUST SYSTEM AND NOISE CONTROL

CV 3.1 Exhaust System General

CV 3.1.1 The exhaust must be routed so that the driver is not subjected to fumes at any speed considering the draft of the vehicle.

CV 4 Electric System and Shutdown System

- CV 3.1.2 The exhaust outlet(s) must not extend more than 450 mm behind the centerline of the rear axle and shall be no more than 600 mm above the ground.
- CV 3.1.3 Any exhaust components (headers, mufflers, etc.) that protrude from the side of the body in front of the main hoop must be shielded to prevent contact by persons approaching the vehicle or a driver exiting the vehicle. The temperature of the outer surface must not be harmful to a person touching it.
- CV 3.1.4 The application of fibrous/absorbent material, e.g. “headerwrap”, to the outside of an exhaust manifold or exhaust system is prohibited.

CV 3.2 Maximum Sound Level

- CV 3.2.1 The maximum sound level test speed for a given engine will be the engine speed that corresponds to an average piston speed of 15.25 m/s. The calculated speed will be rounded to the nearest 500 rpm. The maximum permitted sound level up to this calculated speed is 110 dB(C), fast weighting.
- CV 3.2.2 The idle test speed for a given engine will be up to the team and determined by their calibrated idle speed. If the idle speed varies then the vehicle will be tested across the range of idle speeds determined by the team. At idle the maximum permitted sound level is 103 dB(C), fast weighting.

CV 4 ELECTRIC SYSTEM AND SHUTDOWN SYSTEM

CV 4.1 Shutdown Circuit

- CV 4.1.1 The shutdown circuit directly controls all electrical current to the ignition, fuel injectors and all fuel pumps. It may act through a relay.
- CV 4.1.2 The shutdown circuit is defined as a series connection of at least the cockpit-mounted shutdown button, the BOTS, see T 5.2, and the inertia switch, T 10.5.

CV 4.2 Master Switch

- CV 4.2.1 The vehicle must have one master switch according to T 10.1.
- CV 4.2.2 The master switch must disable power from the battery and the alternator to all electrical circuits, including lights, fuel pump(s), ignition, electrical controls.
- CV 4.2.3 The master switch must be mounted in the middle of a completely red circular area of ≥ 35 mm diameter.
- CV 4.2.4 The master switch must be marked by a symbol showing a red spark in a white edged blue triangle.

CV4 Electric System and Shutdown System

CV4.3 Shutdown Buttons

- CV4.3.1 Shutdown buttons must be a push-pull or push-rotate mechanical emergency switch where pushing the button opens the shutdown circuit (CV4.1).
- CV4.3.2 One shutdown button serves as a cockpit-mounted shutdown button. This cockpit-mounted shutdown button must:
- Have a minimum diameter of 24 mm.
 - Have the international electrical symbol consisting of a red spark on a white-edged blue triangle affixed in close proximity to this switch.
 - Be located to provide easy actuation by the driver in an emergency or panic situation.
 - Be located within easy reach of a belted-in driver.
 - Be alongside the steering wheel and unobstructed by the steering wheel or any other part of the vehicle.
- CV4.3.3 [DV ONLY] In addition to the cockpit mounted shutdown button, the shutdown circuit of DV with internal combustion engine must include two emergency shutdown buttons (as for electric vehicles, see EV7.3 and especially EV7.3.4). These and the Remote Emergency System (RES) as defined in DV1.4 have the same functionality as the cockpit-mounted shutdown button, thus opening the shutdown circuit (see DV1.5 for additional requirements)

CV4.4 Voltage Limit for CV

The maximum permitted voltage between any two electrical connections is 60 VDC or 25 VACRMS. The following systems are excluded from this voltage limit:

- High voltage systems for ignition
- High voltage systems for injectors
- Voltages internal to OEM charging systems designed for <60 VDC output.

EV ELECTRIC VEHICLES

EV 1 ELECTRIC SYSTEM DEFINITIONS

EV 1.1 Grounded Low Voltage System (GLVS) and Tractive System (TS)

EV 1.1.1 The TS of the vehicle is defined as every part that is electrically connected to the motor(s) and TS accumulators.

EV 1.1.2 The GLVS of the vehicle is defined as every electrical part that is not part of the TS.

EV 2 ELECTRIC POWERTRAIN

EV 2.1 Motors

EV 2.1.1 Only electric motors are allowed.

EV 2.1.2 Motor attachments must follow T 9.

EV 2.1.3 Motor casings must follow T 6.4.

EV 2.1.4 The motor(s) must be connected to the accumulator through a motor controller.

EV 2.2 Power Limitation

EV 2.2.1 The maximum power drawn from the accumulator must not exceed 80 kW.

EV 2.2.2 Regenerating energy is allowed and unrestricted but only when the vehicle speed is $>5 \text{ km/h}$.

EV 2.3 Brake System Encoder (BSE)

EV 2.3.1 A BSE or switch to measure brake pedal position or brake system pressure must be fitted to check for plausibility, see EV 2.4. [DV ONLY] The BSE must be a pressure type.

EV 2.3.2 The encoder must have a connector that allows disconnection of the encoder signal during technical inspection.

EV 2.3.3 The encoder signal is a SCS, see T 10.4.

EV 2.4 APPS / Brake Pedal Plausibility Check

EV 2.4.1 The commanded motor torque must be 0 Nm if the mechanical brakes are actuated and the APPS (see T 10.3) signals more than 25 % pedal travel at the same time.

EV 3 General Requirements

- EV 2.4.2 The commanded motor torque must remain at 0 Nm until the APPS signals less than 5 % pedal travel, regardless of whether the brakes are still actuated or not.

EV 3 GENERAL REQUIREMENTS

EV 3.1 Grounding

- EV 3.1.1 All electrically conductive parts of the vehicle (e.g. parts made of steel, (anodized) aluminum, any other metal parts, etc.) which are within 100 mm of any TS or GLVS component, the driver harness mounting points and the seat mounting points must have a resistance below 300 m Ω (measured with a current of 1 A) to GLVS ground.

- EV 3.1.2 All parts of the vehicle which may become electrically conductive (e.g. completely coated metal parts, carbon fiber parts, etc.) which are within 100 mm of any TS or GLVS component, must have a resistance below 5 Ω to GLVS ground.

EV 3.2 Overcurrent Protection

- EV 3.2.1 All electrical systems must have appropriate overcurrent protection.

The continuous current rating of the overcurrent protection must not be greater than the continuous current rating of any electrical component, for example wire, busbar, cell or other conductor that it protects.

I.e. if multiple pins of a connector are used to carry currents in parallel, each pin must be appropriately protected.

- EV 3.2.2 All overcurrent protection devices must be rated for the highest voltage in the systems they protect. All devices used must be rated for DC.

- EV 3.2.3 All overcurrent protection devices must have an interrupt current rating which is higher than the theoretical short circuit current of the system that it protects.

- EV 3.2.4 All overcurrent protection devices which are part of the TS must not rely on programmable logic. The overcurrent protection function of unmodified commercially available motor controllers/inverters for the motor outputs may rely on programmable logic.

- EV 3.2.5 The TS high current path through the accumulator(s) must be fused.

EV 4 GROUNDED LOW VOLTAGE SYSTEM (GLVS)

EV 4.1 General Requirements

- EV 4.1.1 The maximum permitted voltage that may occur between any two electrical connections is 60 VDC or 25 V AC RMS.

- EV 4.1.2 The GLVS must be grounded to the chassis.

- EV 4.1.3 The GLVS must not use orange wiring or conduit.

EV 5 TRACTIVE SYSTEM (TS)

EV 5.1 General Requirements

- EV 5.1.1 The maximum permitted voltage that may occur between any two electrical connections is 600 VDC and for motor controller/inverters internal low energy control signals 620 VDC.
- EV 5.1.2 All components in the TS must be rated for the maximum TS voltage.
Printed Circuit Boards (PCBs) are considered as one component. Every input of a PCB connected to the TS must be rated to the maximum TS voltage.
- EV 5.1.3 All components must be rated for the maximum possible temperature which may occur during usage.

EV 5.2 TS System Enclosures

- EV 5.2.1 Every housing or enclosure containing parts of the TS system, must be labeled with (a) reasonably sized sticker(s) according to “ISO 7010-W012” (triangle with black lightning bolt on yellow background). The sticker must also contain the text “High Voltage” if the voltage is more than 60 VDC or 25 V AC.

EV 5.3 Separation of Traction System and Grounded Low Voltage System

- EV 5.3.1 The entire TS and GLVS must be completely galvanically isolated, see IN4.1.2.
- EV 5.3.2 TS and GLVS circuits must be physically segregated such that they are not running through the same conduit or connector, except for interlock circuit connections.
- EV 5.3.3 Where both TS and GLVS are present within an enclosure, they must be separated by insulating barriers made of moisture resistant, UL recognized or equivalent insulating materials rated for 150 °C or higher (e.g. Nomex based electrical insulation), or maintain the following spacing through air, or over a surface (similar to those defined in UL1741):

Voltage	Spacing
$U < 100 \text{ VDC}$	10 mm
$100 \text{ VDC} < U < 200 \text{ VDC}$	20 mm
$U > 200 \text{ VDC}$	30 mm

- EV 5.3.4 Components and cables capable of movement must be positively restrained to maintain spacing.
- EV 5.3.5 If tractive system and GLVS are on the same PCB, they must be on separate well defined areas of the board, each area clearly marked with “TS” or “GLVS”. The outline of the area required for spacing must be marked.

The following spacing is related to the spacing between traces / board areas:

EV 5 Tractive System (TS)

Voltage	Over Surface	Through Air (Cut in board)	Under Coating
0 VDC to 50 VDC	1.6 mm	1.6 mm	1.0 mm
50 VDC to 150 VDC	6.4 mm	3.2 mm	2.0 mm
150 VDC to 300 VDC	9.5 mm	6.4 mm	3.0 mm
300 VDC to 600 VDC	12.7 mm	9.5 mm	4.0 mm

“Under coating” is referring to a coating insulator, solder resist is not a coating. If integrated circuits are used such as opto-couplers which are rated for the respective maximum TS voltage, but do not fulfill the required spacing, then they may still be used and the given spacing does not apply for this integrated circuit.

- EV 5.3.6 Teams must be prepared to demonstrate spacing on team-built equipment. For inaccessible circuitry, fully assembled spare boards must be available.
- EV 5.3.7 All connections to external devices, such as laptops, from a TS component must include galvanic isolation.

EV 5.4 Positioning of Tractive System Parts

- EV 5.4.1 With the exception of what is permitted according to EV 5.4.3, all parts belonging to the TS including cables and wiring must be located within the rollover protection envelope, see T 2.1.1.

“Part” is the whole device such as the complete HVD.

- EV 5.4.2 Any part of the TS that is less than 350 mm above the ground must be shielded from side or rear impact collisions by structure according to T 2.16.
- EV 5.4.3 Outboard wheel motors are allowed even if the motor, attendant cables and wiring are outside of the rollover protection envelope, see T 2.1.1, and only if an interlock is added such that the shutdown circuit, see EV 7, is activated if the wheel assembly is damaged or knocked off the vehicle. The activation of the shutdown circuit must occur before the failure of the TS wiring. TS wiring running outside of the envelope must be reduced to a minimum. The TS wiring must not be able to reach the cockpit opening or the driver regardless of where it breaks.
- EV 5.4.4 In side or front view any part of the TS must not project below the lower surface of the chassis.
- EV 5.4.5 Additional regulations apply for accumulators, see EV 6.4.

EV 5.5 Tractive System Insulation, Wiring and Conduit

- EV 5.5.1 All live parts of the TS must be protected from being touched. This must include team members working on or inside the vehicle. This is tested with a 100 mm long, 6 mm diameter insulated test probe when the TS enclosures are in place.
- EV 5.5.2 Insulation material that is appropriate for the expected surrounding temperatures and rated for the maximum TS voltage must be used. Using only insulating tape or rubber-like paint for insulation is prohibited.

EV 5 Tractive System (TS)

- EV 5.5.3 The minimum acceptable temperature rating for TS wiring, connections and insulation is 90 °C.
- EV 5.5.4 TS components and containers must be protected from moisture in the form of rain or puddles, see IN 9.
- EV 5.5.5 All wires, terminals and other conductors used in the TS must be sized appropriately for the continuous TS current. The wires must be marked with wire gauge, temperature rating and insulation voltage rating or a serial number/norm printed on the wire if clearly bound to the wire characteristics for example by a data sheet.
- Sizing of the conductors for the “continuous TS current” may take account of the Root Mean Square (RMS) or average electrical current that will be used and the anticipated duration of time at maximum electrical current.
- EV 5.5.6 All TS connections must be designed so that they use intentional current paths through conductors such as copper or aluminum and should not rely on steel bolts to be the primary conductor. The connections must not include compressible material such as plastic in the stack-up.
- EV 5.5.7 All electrical connections (including bolts, nuts and other fasteners) in the high current path of the TS must be secured from unintentional loosening by the use of positive locking mechanisms that are suitable for high temperatures, for example prevailing torque nuts, see T 9.2.
- Components, e.g. inverters, certified for automotive use might be allowed without positive locking feature, if connections are completed as recommended by the manufacturers datasheet and no positive locking is possible.
- EV 5.5.8 Teams must be prepared to demonstrate positive locking. For inaccessible connections, appropriate photographs must be available.
- EV 5.5.9 All TS wiring must be completed to professional standards with appropriately sized conductors and terminals and with adequate strain relief and protection from loosening due to vibration etc. .
- EV 5.5.10 TS wiring must be located out of the way of possible snagging or damage.
- EV 5.5.11 All TS wiring that runs outside of TS enclosures must
- Be enclosed in separate orange non-conductive conduit or use an orange shielded cable.
 - Be securely anchored at least at each end so that it can withstand a force of 200 N without straining the cable end crimp.
- Body work is not sufficient to meet this enclosure requirement.
- EV 5.5.12 Any shielded cable must have the shield grounded.
- EV 5.5.13 Every TS connector outside of a housing must include a pilot contact/interlock line which is part of the shutdown circuit. Housings only used to avoid interlocks are prohibited.
- EV 5.5.14 Soldered connections in the high current path are only allowed if all of the following are true:
- connections on PCBs
 - the connected devices are not cells or wires

EV 5 Tractive System (TS)

- the devices are additionally mechanically secured against loosening

EV 5.6 Data Logger

- EV 5.6.1 A calibrated data logger will be provided by the officials and must be inserted during competition. The data logger measures TS voltage and TS current.
- EV 5.6.2 The data logger must be in an easily accessible location so that it is possible to insert, remove or replace it within 15 min in ready to race condition.
- EV 5.6.3 The data logger must not be placed within the accumulator container.
- EV 5.6.4 All current supplying the TS must run through the data logger. The data logger must be inserted in the negative tractive system supply between the most negative AIR(s) and the inverters.
- EV 5.6.5 The TS voltage sense connection of the data logger must be directly connected to the most positive AIR(s) on vehicle side.
- EV 5.6.6 The data logger must be directly supplied from the GLVS master switch.
- EV 5.6.7 The specification of the data logger will be available on the competition website.

EV 5.7 Tractive System Measuring point (TSMP)

- EV 5.7.1 Two TSMPs must be installed directly next to the master switches, see EV 7.2.
- EV 5.7.2 The TSMPs must be protected by a non-conductive housing that can be opened without tools.
- EV 5.7.3 4 mm shrouded banana jacks of rated for 1000 V CAT III or better must be used for the TSMPs.
- EV 5.7.4 The TSMPs must be directly connected to the positive and negative motor controller/inverter supply.
- EV 5.7.5 The TSMPs must be marked “TS+” and “TS-” and must be mounted on an orange background.
- EV 5.7.6 Each TSMP must be secured with a current limiting resistor according to the following table. Fusing of the TSMPs is prohibited. The resistors power rating must be chosen such that they are able to continuously carry the current if both TSMPs are short circuited.

Maximum TS Voltage	Resistor Value
$U_{max} < 200 \text{ VDC}$	5 k Ω
$200 \text{ VDC} < U_{max} \leq 400 \text{ VDC}$	10 k Ω
$400 \text{ VDC} < U_{max} \leq 600 \text{ VDC}$	15 k Ω

- EV 5.7.7 Next to the TSMPs a GLVS ground measuring point must be installed. A 4 mm black shrouded banana jack must be connected to GLVS ground and must be marked “GND”.

EV 5 Tractive System (TS)

EV 5.8 High Voltage Disconnect (HVD)

- EV 5.8.1 It must be possible to disconnect at least one pole of the TS accumulator by quickly removing an unobstructed and directly accessible element, fuse or connector. It must be possible to disconnect the HVD without removing any bodywork. The HVD must be above 350 mm from the ground and easily visible when standing behind the vehicle. Remote actuation of the HVD through a long handle, rope or wire is not permitted.
- EV 5.8.2 An untrained person must be able to remove the HVD within 10 seconds when the vehicle is in ready-to-race condition.
- EV 5.8.3 EV 5.5 remains valid, therefore a dummy connector or similar may be required to restore the system's isolation.
- EV 5.8.4 The HVD must be clearly marked with "HVD".
- EV 5.8.5 No tools must be necessary to open the HVD. Therefore, a pilot contact/interlock must open the shutdown circuit when the HVD is removed.

EV 5.9 Discharge Circuit

- EV 5.9.1 If a discharge circuit is required to meet EV 7.1.5, it must be designed to handle the maximum tractive system voltage permanently.
- After three subsequent discharges within 15s in total, the discharge time specified in EV 7.1.5 may be exceeded.. Full discharging functionality must be given after a reasonable time with a deactivated discharge circuit.
- EV 5.9.2 The discharge circuit must be wired in a way that it is always active whenever the shutdown circuit is open. Furthermore, the discharge circuit must be fail-safe such that it still discharges the intermediate circuit capacitors if the HVD has been opened.
- EV 5.9.3 Fusing of the discharge main current path is prohibited.

EV 5.10 Tractive System Active Light (TSAL)

- EV 5.10.1 The vehicles must include a single TSAL that must indicate the TS status. The TSAL must not perform any other functions. A TSAL with multiple LEDs in one housing is allowed.
- EV 5.10.2 The TS is active when ANY of the following conditions are true:
- An accumulator isolation relay is closed.
 - The pre-charge relay, see EV 6.7.3, is closed.
 - The voltage outside the accumulator container(s) exceeds 60 VDC or 25 V AC RMS. This implies that at least the voltage of all DC-link capacitors need to be measured even with the HVD removed.
- EV 5.10.3 The TS is deactivated when ALL of the following conditions are true:
- All accumulator isolation relays are opened.
 - The pre-charge relay, see EV 6.7.3, is opened.

EV 5 Tractive System (TS)

- The voltage outside the accumulator container(s) does not exceed 60 VDC or 25 V AC RMS. This implies that at least the voltage of all DC-link capacitors need to be measured even with the HVD removed.
- EV 5.10.4 The mentioned states of the relays (opened/closed) are the actual mechanical states. The mechanical state can differ from the intentional state, i.e. if a relay is stuck.
- EV 5.10.5 The TSAL itself must:
- Be hard wired electronics. Software control is not permitted.
 - Be red in color and flash continuously with a frequency between 2 Hz and 5 Hz if the TS is active, see EV 5.10.2, and the GLVS is switched on.
 - Be green in color and continuously illuminated if the TS is deactivated, see EV 5.10.3, and the GLVS is switched on.
- EV 5.10.6 The TSAL must:
- Be located lower than the highest point of the main hoop and within the rollover protection envelope, see T 2.1.1.,.
 - Be no lower than 150 mm from the highest point of the main hoop.
 - Not be able to contact the driver's helmet in any circumstances.
- EV 5.10.7 The TSAL must be clearly visible:
- Except for small angles which are blocked by the main hoop.
 - From a point 1.60 m vertically from ground level, within 3 m horizontal radius from the TSAL.
 - In direct sunlight.
- EV 5.10.8 Signals influencing the TSAL are SCS, see T 10.4. The circuitry detecting the relay conditions mentioned in EV 5.10.2 and EV 5.10.3 does not need to detect an open circuit when the intentional state of the relay is opened. The TSAL has an active indication of absence of failures (green light) and thus must not be illuminated for visible check, see T 10.4.4.
- EV 5.10.9 If an TS accumulator container is removed from the vehicle, a device must be used which logically replaces the TSAL parts inside the accumulator container. It must not be possible to electrically connect the accumulator container to the vehicle when this device is in place.

EV 5.11 Activating the Tractive System

- EV 5.11.1 The driver must be able to activate and deactivate the TS, see EV 5.10.2 and EV 5.10.3, from within the cockpit without the assistance of any other person.
- EV 5.11.2 Closing the shutdown circuit by any part defined in EV 7.1.2 must not (re-)activate the tractive system. Additional action must be required.
- EV 5.11.3 [DV ONLY] The autonomous system must not be able to (re-)activate the TS.
- EV 5.11.4 The vehicle is ready to drive as soon as the motor(s) will respond to the input of the APPS.

EV 6 Tractive System Energy Storage

- EV 5.11.5 After the TS has been activated, additional actions must be required by the driver to set the vehicle to ready-to-drive mode (e.g. pressing a dedicated start button). One of these actions must include the actuation of the mechanical brakes while ready-to-drive mode is entered.
- EV 5.11.6 The ready-to-drive mode must be left immediately when the shutdown circuit is opened.

EV 5.12 Ready-To-Drive Sound

- EV 5.12.1 The vehicle must make a characteristic sound, continuously for at least one second and a maximum of three seconds when it enters ready-to-drive mode.
- EV 5.12.2 The sound level must be a minimum of 80 dBA and a maximum of 90 dBA, fast weighting. The sound level will be measured with a free-field microphone placed free from obstructions in a radius of 2 m around the vehicle.
- EV 5.12.3 The used sound must be easily recognizable. No animal voices, song parts or sounds that could be interpreted as offensive will be accepted.
- EV 5.12.4 The vehicle must not make any other sounds similar to the ready-to-drive sound.

EV 6 TRACTIVE SYSTEM ENERGY STORAGE

EV 6.1 General Definitions

- EV 6.1.1 The TS accumulator is defined as all the battery cells or super-capacitors that store the electrical energy to be used by the TS.
- EV 6.1.2 Accumulator segments are sub-divisions of the accumulator.
- EV 6.1.3 The energy of a cell is defined by the maximum cell voltage times the nominal capacity of the used cell.

EV 6.2 Allowed Tractive System Accumulators

- EV 6.2.1 All types of accumulators except molten salt and thermal batteries are allowed.
- EV 6.2.2 Fuel cells are prohibited.

EV 6.3 Tractive System Accumulator – General Requirements

- EV 6.3.1 All cells or super-capacitors which store the TS energy will be built into accumulator segments and must be enclosed in (an) accumulator container(s).
- EV 6.3.2 Each accumulator segment must not exceed a maximum static voltage of 120 VDC and a maximum energy of 6 MJ, see EV 6.1.3.
- EV 6.3.3 If spare accumulators are used, they must be of the same size, weight and type as those that are replaced. Spare accumulator packs must be presented at technical inspection.
- EV 6.3.4 It must be possible to open the accumulator container for technical inspection.

EV 6 Tractive System Energy Storage

EV 6.3.5 Each accumulator container must be removable from the vehicle while still remaining rules compliant without the need to install extra components.

EV 6.3.6 The vehicle number, the university name and the ESO phone number(s) must be displayed and written in Roman Sans-Serif characters of at least 20 mm high on the lid of each accumulator container. The characters must be clearly visible and placed on a high contrast background.

EV 6.4 Tractive System Accumulator – Electrical Configuration

EV 6.4.1 If the container is made from an electrically conductive material, the insulation barrier must be adequately protected against conductive penetrations.

EV 6.4.2 Every accumulator container must contain at least one fuse and at least two accumulator isolation relays, see EV 6.6 and EV 3.2.

EV 6.4.3 GLVS must not be included in the accumulator container except where inherently required. Exceptions include the AIRs, HV DC/DC converters, the Accumulator Management System (AMS), the IMD and cooling fans.

EV 6.4.4 Maintenance plugs, additional contactors or similar must allow electrical separation of all internal cell segments, see EV 6.3.2. The separation must affect both poles of all segments including first and last segment.

EV 6.4.5 Maintenance plugs must not require tools to separate the segments. Maintenance plugs must be non-conductive on surfaces that do not provide any electrical connection.

EV 6.4.6 It must not be physically possible to electrically connect the maintenance plugs in any way other than the design intent configuration.

EV 6.4.7 Each segment must be electrically insulated by the use of suitable material between the segments in the container and on top of the segment to prevent arc flashes caused by inter segment contact or by parts/tools accidentally falling into the container during maintenance. Air is not considered to be a suitable insulation material in this case.

EV 6.4.8 Every wire used in an accumulator container, regardless of whether it is part of the GLVS or TS, must be rated to the maximum TS voltage.

EV 6.4.9 Each accumulator container must have a prominent indicator, a voltmeter or a red LED visible even in bright sunlight that will illuminate whenever a voltage greater than 60 VDC or half the nominal TS voltage, whichever is lower, is present at the vehicle side of the AIRs.

EV 6.4.10 The indicator must be clearly visible while disconnecting the accumulator container from the vehicles. The indicator must be clearly marked with “Voltage Indicator”

EV 6.4.11 The indicator must be hard wired electronics without software control and directly supplied by the TS and always working, even if the accumulator is disconnected from the GLV system or removed from the vehicle.

EV 6.5 Tractive System Accumulator – Mechanical Configuration

EV 6.5.1 All accumulator containers must lie within and be attached to the primary structure no higher than the top of the side impact structure, see T2.1.

EV 6 Tractive System Energy Storage

- EV 6.5.2 All accumulator container materials must be fire resistant according to UL94-V0, FAR25 or equivalent.
- EV 6.5.3 The accumulator containers must be protected from side or rear impact collisions by structure equivalent to that defined in T 2.3. The container must not be part of this structure.
- EV 6.5.4 The design of the accumulator must be documented in the SES including materials used, drawings, images, fastener locations, segment weight, cell and segment position.
- EV 6.5.5 Accumulator containers must be constructed of steel or aluminium. With the following requirements:
- The bottom of the accumulator container must be at least 1.25 mm thick if made from steel or 3.2 mm if made from aluminium.
 - The internal and external vertical walls, covers and lids must be at least 0.9 mm thick if made from steel or 2.3 mm if made from aluminium.
- Alternative materials are allowed with proof of equivalency per T2.4 or for composite materials per EV 6.5.6. This must be documented in the SES. When alternative materials are used, test samples must be presented at technical inspection.
- EV 6.5.6 Composite accumulator containers must satisfy the following requirements:
- Data obtained from the laminate perimeter shear strength test and three point bending test (T2.6) should be used to prove adequate strength is provided.
 - Each attachment point requires steel backing plates with a minimum thickness of 2 mm. Alternate materials may be used for backing plates if equivalency is approved.
 - The calculations and physical test results must be included in the SES.
- EV 6.5.7 Internal vertical walls must divide the accumulator container into “sections”. A maximum of 12 kg is allowed in any “section”.
- EV 6.5.8 The accumulator segments, see EV 6.3.2, must be separated by an electrically insulating and fire resistant barrier according to UL94-V0, FAR25 or equivalent.
- EV 6.5.9 Vertical walls separating cells and/or segments must be a minimum of 75 % of the height of the external vertical walls.
- EV 6.5.10 The floor and walls of the accumulator container must be joined by welds, bonding and/or fasteners.
- EV 6.5.11 The cells and/or segments must be appropriately secured against loosening inside the container.
- EV 6.5.12 The mounting of the accumulator must be designed to withstand the following accelerations:
- 40 g in the longitudinal direction (forward/aft)
 - 40 g in the lateral direction (left/right)
 - 20 g in the vertical direction (up/down)
- Calculations and/or tests must be documented in the SES.
- EV 6.5.13 All fasteners used within or to mount the accumulator container must comply with T9. Fasteners within the accumulator used for non-structural accumulator parts (e.g. PCBs etc.) do not have to follow T9 if the fasteners are made of electrically non-conductive material.

EV 6 Tractive System Energy Storage

- EV 6.5.14 The AIRs and the main fuse must be separated with an electrically insulated and fireproof material to UL94-V0 from the rest of the accumulator. Air is not considered to be a suitable insulation material in this case.
- EV 6.5.15 Any brackets used to mount the accumulator container must be made of steel 1.6 mm thick or aluminium 4 mm thick and must have gussets to carry bending loads. Each attachment point including brackets, backing plates and inserts, must be able to withstand 20 kN in any direction.
- EV 6.5.16 Holes, both internal and external, in the container are only allowed for the wiring-harness, ventilation, cooling or fasteners. External holes must be sealed according to EV 5.5.
- EV 6.5.17 A sticker according to “ISO 7010-W012” (triangle with black lightning bolt on yellow background) with triangle side length of at least 100 mm and the text “Always Energized” must be applied on every accumulator container. The sticker must also contain the text “High Voltage” if the voltage is more than 60 V DC or 25 V AC.
- EV 6.5.18 Any accumulators that may vent an explosive gas must have a ventilation system to prevent the vented gas from reaching an explosive concentration.
- EV 6.5.19 Every accumulator container which is completely sealed must also have a pressure relief valve to prevent high-pressure in the container.
- EV 6.5.20 Cell tabs must not carry mechanical loads.

EV 6.6 Accumulator Isolation Relays (AIRs)

- EV 6.6.1 At least two AIRs must be fitted inside each accumulator container.
- EV 6.6.2 The AIRs must open both poles of the accumulator. If the AIRs are open, no TS voltage may be present outside of the accumulator container.
- EV 6.6.3 The AIRs must be of a “normally open” type.
- EV 6.6.4 The fuse protecting the accumulator TS circuit must have a rating lower than the maximum switch off current of the AIRs.
- EV 6.6.5 The AIRs must not contain mercury.
- EV 6.6.6 The AIRs must be mechanical relays. Solid-state relays are prohibited.

EV 6.7 Pre-Charge Circuit

- EV 6.7.1 A circuit that ensures that the intermediate circuit is pre-charged to at least 90 % of the actual accumulator voltage before closing the second AIR must be implemented. Therefore the intermediate circuit voltage must be measured.
- EV 6.7.2 Any pre-charge circuitry must be supplied by the shutdown circuit directly from the TSMS. The circuit must be disabled by an opened shutdown circuit, see EV 7.
- EV 6.7.3 The pre-charge circuit must use a mechanical, normally open type relay. All pre-charge current must pass through this relay.

EV 6 Tractive System Energy Storage

EV 6.8 Accumulator Management System (AMS)

- EV 6.8.1 Each accumulator must be monitored by an AMS whenever the GLVS is active or the accumulator is connected to a charger.
- EV 6.8.2 The AMS must continuously measure
- (a) all cell voltages
 - (b) the accumulator current
 - (c) the temperature of thermally critical cells
 - (d) for lithium based cells: the temperature of at least 30 % of the cells equally distributed within the accumulator container(s)
- EV 6.8.3 Cell temperature must be measured at the negative terminal of the respective cell and the sensor used must be in direct contact with either the negative terminal or less than 10 mm away from the terminal on the respective busbar. It is acceptable to monitor multiple cells with one sensor if this requirement is met for all cells sensed by the sensor.
- EV 6.8.4 The maximum cell temperature is 60 °C or the limit stated in the cell data sheet, whichever is lower.
- EV 6.8.5 An independent cell temperature monitoring device may be provided by the officials during accumulator inspection and must be installed, see IN 3.
- The device must be placed on the warmest negative cell terminal of the accumulator container and in direct contact with the terminal or no less than 30 mm away from it on the busbar.
- EV 6.8.6 The AMS must switch off the TS via the shutdown circuit, if critical voltage, temperature or current values according to the cell manufacturer's datasheet or these rules are persistently detected. for more than:
- (a) 500 ms for voltage and current values
 - (b) 1 s for temperature values
- The accuracy and noise of the measurement must be taken into account for these.
- EV 6.8.7 AMS cell voltage measurement inputs, temperature measurement inputs and supply voltage of decentralized AMS slaves may be rated below the maximum TS voltage if the team has proven by calculations in the Electrical System Form (ESF), see EV 10, that the input voltage rating is reasonably chosen.
- EV 6.8.8 A red indicator light in the cockpit that is easily visible even in bright sunlight and clearly marked with the lettering "AMS" must light up if the AMS opens the shutdown circuit. It must stay illuminated until the error state has been manually reset, see EV 7.1.6. Signals controlling this indicator are SCS, see T 10.4.
- EV 6.8.9 AMS signals are System Critical Signals, see T 10.4.
- EV 6.8.10 The AMS must be able to read and display all measured values according to EV 6.8.2 e.g. by connecting a laptop to the AMS.

EV7 SHUTDOWN CIRCUIT AND SYSTEMS

EV7.1 Shutdown Circuit

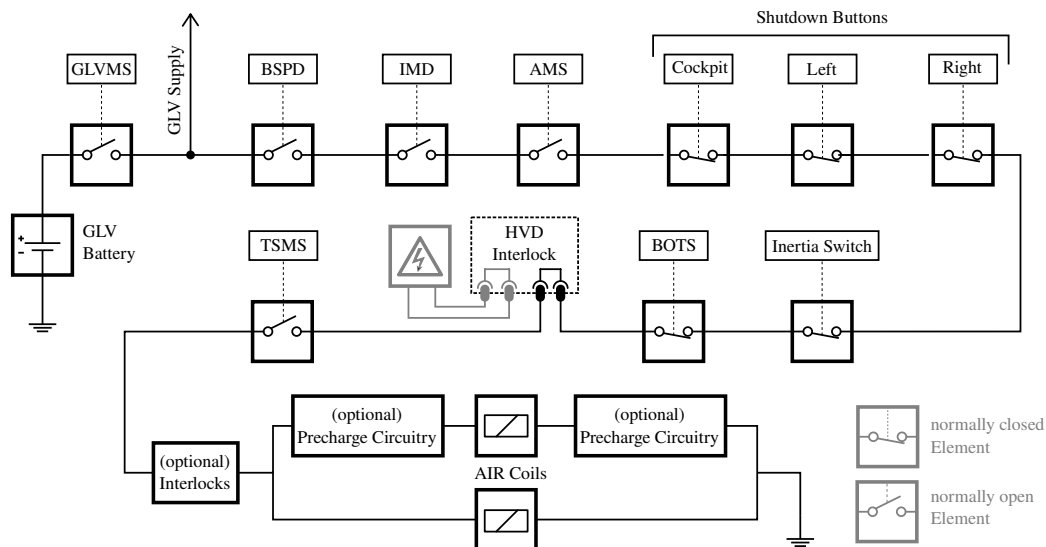

Figure 18: Explanatory example schematic of the required shutdown circuit

- EV 7.1.1 The shutdown circuit directly carries the current driving the AIRs.
- EV 7.1.2 The shutdown circuit is defined as a series connection of at least two master switches, three shutdown buttons, the BOTS, see T 5.2, the IMD, the inertia switch, see T 10.5, the BSPD, all required interlocks and the AMS.
An explanatory schematic of the required shutdown circuit, excluding any possible interlock circuitry, is shown in Figure 18.
- EV 7.1.3 All parts of the shutdown circuit must be on the high-side connection of the AIR coils.
- EV 7.1.4 The Tractive System Master Switch (TSMS), see EV 7.2, must be the last switch before the AIRs except for pre-charge circuitry and hardwired interlocks.
- EV 7.1.5 If the shutdown circuit is opened, the TS must be shutdown by opening all AIRs and the voltage in the TS must drop to below 60 VDC and 25 V ACRMS in less than five seconds. All accumulator current flow must stop immediately.
The action of opening the shutdown circuit may be delayed by ≤ 250 ms to signal the action to the motor controllers and reduce the TS current before the AIRs are opened. The AIR supply must be abruptly switched off before reaching the minimum AIR supply voltage.
- EV 7.1.6 If the shutdown circuit is opened by the AMS or the IMD, the TS must remain disabled until it is manually reset at the vehicle, by a person who is not the driver. This must be achieved by non-programmable circuits.
For example: Applying an IMD test resistor between HV+ and GLVS ground must deactivate the system. Disconnecting the test resistor must not re-activate the system.

EV7 Shutdown Circuit and Systems

- EV 7.1.7 All circuits that are part of the shutdown circuit must be designed in a way, that in the de-energized/disconnected state they are open such that each circuit will remove the current controlling the AIRs.
- EV 7.1.8 If the TS is de-activated while driving, the motor(s) has/have to spin freely e.g. no brake torque may be applied to the motor(s).
- EV 7.1.9 It must be possible to demonstrate that all features of the shutdown circuit function correctly. This includes all interlocks.
- EV 7.1.10 Every system that is required to or is able to open the shutdown circuit must have its own, non-programmable, power stage to achieve this. The respective power stages must be designed to be able to carry the shutdown circuit current, e.g. AIR inrush currents, and such that a failure cannot result in electrical power being fed back into the electrical shutdown circuit.
- EV 7.1.11 The shutdown buttons, the BOTS, the TSMS and all interlocks must not act through any power stage, but must directly carry the AIR current.
- EV 7.1.12 All signals influencing the shutdown circuit are SCSs, see T 10.4.

EV 7.2 Master Switches

- EV 7.2.1 Each vehicle must have two master switches, the Grounded Low Voltage Master Switch (GLVMS) and the Tractive System Master Switch (TSMS), each according to T 10.1.
- EV 7.2.2 The GLVMS must completely disable power to the GLVS.
- EV 7.2.3 The TSMS must be fitted with a “lockout/tagout” capability to prevent accidental activation of the TS. The ESO must ensure that it is locked in the off position whenever work is done on the vehicle or no ESO is present.
- EV 7.2.4 The master switches must not be easily removable, e.g. they must not be mounted onto removable body work.
- EV 7.2.5 The GLVMS must be mounted in the middle of a completely red circular area of ≥ 35 mm diameter.
- EV 7.2.6 The GLVMS must be marked with “GLVS” and a symbol showing a red spark in a white edged blue triangle.
- EV 7.2.7 The TSMS must be mounted in the middle of a completely orange circular area of ≥ 35 mm diameter.
- EV 7.2.8 The TSMS must be marked with “TS” and a symbol according to “ISO 7010-W012” (triangle with black lightning bolt on yellow background).

EV 7.3 Shutdown Buttons

- EV 7.3.1 A system of three shutdown buttons must be installed on the vehicle.
- EV 7.3.2 Pressing any one of the shutdown buttons must separate the TS from the accumulator by opening the shutdown circuit, see also EV 7.1.

EV7 Shutdown Circuit and Systems

- EV 7.3.3 Each shutdown button must be a push-pull or push-rotate mechanical emergency switch where pushing the button opens the shutdown circuit.
- EV 7.3.4 One button must be located on each side of the vehicle behind the driver's compartment at approximately the level of the driver's head. The minimum allowed diameter of the shutdown buttons on both sides of the vehicle is 40 mm.
- EV 7.3.5 One shutdown button serves as a cockpit-mounted shutdown button. The minimum allowed diameter of the shutdown button in the cockpit is 24 mm. It must be in easy reach of the driver, even when he/she is belted in. It must be alongside the steering wheel and unobstructed by the steering wheel and any other part of the vehicle.
- EV 7.3.6 The international electrical symbol consisting of a red spark on a white-edged blue triangle must be affixed in close proximity to each shutdown button.
- EV 7.3.7 The shutdown buttons must be permanently fixed and should not be easily removable, e.g. they must not be mounted onto removable body work.

EV7.4 Insulation Monitoring Device (IMD)

- EV 7.4.1 Every vehicle must have an IMD installed in the HV system.
- EV 7.4.2 The IMD must be a Bender A-ISOMETER[®] iso-F1 IR155-3203 or -3204 or equivalent IMD approved for automotive use. Equivalency may be approved by the officials based on the following criteria: robustness to vibration, operating temperature range, IP rating, availability of a direct output, a self-test facility and must not be powered by the system which is monitored.
- EV 7.4.3 The response value of the IMD must be set to $\leq 500 \Omega/v$, related to the maximum TS operation voltage.
- EV 7.4.4 In case of an insulation failure or an IMD failure, the IMD must open the shutdown circuit. This must be done without the influence of any programmable logic. See also EV 7.1.6 regarding the re-activation of the TS after an insulation fault.
- EV 7.4.5 A red indicator light in the cockpit that is easily visible even in bright sunlight and clearly marked with the lettering "IMD" must light up if the IMD opens the shutdown circuit. It must stay illuminated until the error state has been manually reset, see EV 7.1.6. Signals controlling this indicator are SCS, see T 10.4.

EV7.5 Brake System Plausibility Device (BSPD)

- EV 7.5.1 A standalone non-programmable circuit must permanently open the shutdown circuit when hard braking (without locking the wheels) occurs, whilst power is delivered to the motors. Only power cycling the GLVMS may reset this functionality and close the shutdown circuit again.
- EV 7.5.2 Standalone is defined as there is no additional functionality implemented on all required PCB(s). The interfaces must be reduced to the minimum necessary signals.
- EV 7.5.3 The BSPD must be directly supplied from the GLVS master switch.

EV 8 Chargers

- EV 7.5.4 The BSPD including all required sensors must not be installed inside the accumulator container.
- EV 7.5.5 The current limit for triggering the circuit must be set at a level where ≤ 5 kW of electrical power in the DC circuit is delivered to the motors at the nominal battery voltage.
- EV 7.5.6 The action of opening the shutdown circuit must occur if the implausibility is persistent for more than 500 ms.
- EV 7.5.7 All necessary signals are system critical signals, see T 10.4.
- EV 7.5.8 The team must prove the function of the BSPD during technical inspection by sending an appropriate signal to the non-programmable circuit that represents the current, in order to achieve ≤ 5 kW whilst pressing the brake pedal hard. This test must prove the functionality of the complete BSPD except for any commercially available current sensors.

EV 8 CHARGERS

EV 8.1 Chargers General Requirements

- EV 8.1.1 Only chargers presented and sealed at technical inspection are allowed. All connections of the charger(s) must be isolated and covered. No open connections are allowed.
- EV 8.1.2 All chargers must either be accredited to a recognized standard e.g. CE, or when built by the team, must comply with all electrical requirements for the vehicle TS, e.g. EV 5.3, EV 3.1 and EV 5.2.
- EV 8.1.3 TS charging leads must be orange.
- EV 8.1.4 When charging, the AMS must be live and must be able to turn off the charger in the event that a fault is detected.
- EV 8.1.5 The charger must include a push type emergency stop button which has a minimum diameter of 24 mm and must be clearly labeled.
- EV 8.1.6 When charging the accumulator, an IMD as described in EV 7.4 must be active and must be able to shut down the charger. Either the charger must incorporate an active IMD or an active IMD must be within the accumulator. An IMD indicator light must be available during charging.
- EV 8.1.7 The charger must include TSMPs as described in EV 5.7. Other than stated, the TSMPs must be connected to the HV output of the charger.

EV 8.2 Charging Shutdown Circuit

- EV 8.2.1 When charging, the charging shutdown circuit consists of at least the charger shutdown button, see EV 8.1.5, the IMD and the AMS.
- EV 8.2.2 If the shutdown circuit is opened the charging system must remain disabled until it is manually reset.
- EV 8.2.3 The charging shutdown systems must comply with EV 7.1.1, EV 7.1.5, EV 7.1.7, EV 7.1.9 and EV 7.1.10.

EV9 Tractive System Procedures and Tools

EV 8.2.4 All signals influencing the charger shutdown circuit are System Critical Signals (SCSs), see T10.4.

EV 9 TRACTIVE SYSTEM PROCEDURES AND TOOLS

EV 9.1 Working on the Tractive System

EV 9.1.1 Activities on the TS, except for the accumulator (see EV 9.2) must take place in the pit.

EV 9.1.2 All activities require the attendance of the ESO.

EV 9.1.3 For activities on the inactive TS, the following procedure must be carried out:

1. Barrier off the vehicle from anyone not involved in the work, by using barrier tape.
2. Make sure the Tractive System Master Switch (TSMS) is switched off.
3. Assure that the TS cannot be restarted, by, at a minimum, using the lockout/tag out of the TSMS.
4. Check for zero-potential.
5. Install a sign that declares the vehicle is electrically safe. Make a note of the name of an ESO who is supervising the activities on the sign. This ESO is the only person who may remove the sign and the barrier.

EV 9.1.4 In case of measurements on the active TS or an activation of the TS in the pit for testing purposes, the following steps must be followed:

- Barrier off the vehicle from anyone not involved in the work, by using barrier tape.
- The vehicle must be jacked up and the driven wheels removed.
- One team member must be prepared to push a shutdown button at any time.
- The TS must only be activated for as long as necessary.
- Appropriate insulated tools and equipment must be used.
- Safety glasses with side shields and compliant safety gloves must be worn by all participating team members when parts of the TS are exposed.
- No other work on the vehicle is permitted when the TS is active.

EV 9.1.5 If the TSAL is flashing red or malfunctioning, the TS is considered as active.

EV 9.1.6 There must be at least one team member present, who is not directly involved in the work, but who could assist in case of an incident.

EV 9.2 Working on Tractive System Accumulators

EV 9.2.1 Opening or working on accumulator containers is only allowed in the provided work places in the charging area, see EV 9.3.

EV 9.2.2 All activities require the attendance of an ESO.

EV 9.2.3 Whenever the accumulator containers are opened, the cell segments must be separated with the maintenance plugs, see EV 6.4.4.

EV 10 Electrical System Form (ESF)

- EV 9.2.4 Appropriate insulated tools and equipment must be used.
- EV 9.2.5 Safety glasses with side shields and compliant safety gloves must be worn by all participating team members.
- EV 9.2.6 There must be at least one team member present, who is not directly involved in the work conducted on the accumulator, but who could assist in case of an incident.
- EV 9.2.7 Additional safety measures may be included in the respective competition handbook.

EV 9.3 Charging

- EV 9.3.1 There will be a separated charging area on the competition site. Charging TS accumulators is only allowed inside this area.
- EV 9.3.2 Accumulators must be removed from the vehicle and placed on the accumulator container hand cart, see EV 9.4, for charging.
- EV 9.3.3 The label EV 6.3.6 or an additional label according to EV 6.3.6 must be visible during charging.
- EV 9.3.4 No grinding, drilling, etc. is allowed in the charging area.
- EV 9.3.5 At least one team member who has knowledge of the charging process must stay with the accumulator(s) during charging.
- EV 9.3.6 Moving accumulator cells and/or accumulator segment(s) around at the competition site is only permitted if they are inside a completely closed accumulator container.

EV 9.4 Accumulator Container Hand Cart

- EV 9.4.1 The hand cart(s) must be used for transporting the accumulator container(s) around the competition site.
- EV 9.4.2 The hand cart must have a brake which is always on and only released if someone pushes the handle, or similar.
- EV 9.4.3 The brake must be capable of stopping the fully loaded accumulator container hand cart.
- EV 9.4.4 The hand cart must be able to carry the load of the accumulator container(s).

EV 10 ELECTRICAL SYSTEM FORM (ESF)

EV 10.1 Electrical System Form (ESF)

- EV 10.1.1 Prior to the competition, all teams must submit clearly structured documentation of their entire electrical system (including control and TS) called the ESF.
- EV 10.1.2 It is the teams responsibility to create the ESF on the competition website before the deadline specified in the competition handbook.

DV DRIVERLESS VEHICLES

DV 1 VEHICLE REQUIREMENTS AND RESTRICTIONS

DV 1.1 Base Vehicle

Additions to the vehicle's general requirements and restrictions are marked and given in T, and CV or EV depending on the implemented drivetrain. Please also refer to rule A 2.3.

DV 1.2 Wireless Communication

DV 1.2.1 During dynamic events, wireless communication is limited to ensure that the vehicle is driving autonomously. It is prohibited to change parameters, send commands or make any software changes by wireless communication.

DV 1.2.2 An exception is the RES described in DV 1.4. Receiving information from the vehicle via one-way-telemetry is allowed.

DV 1.2.3 (D)GPS may be used, but there will be no space to securely build up base stations on the competition site.

DV 1.3 Data logger

DV 1.3.1 The officials will provide a standardized data logger that must be installed in any DV during the competition. Further specifications for the data logger and required hardware and software interfaces can be found in the competition handbook.

DV 1.3.2 The intention of the data logger is to understand and reproduce the system state in case of failure. This includes a basic set of signals defined in the competition handbook and the set of vehicle-individual signals that have to be monitored by the Emergency Brake System (EBS) to ensure redundancy and fault detection.

DV 1.3.3 Vehicle software or algorithms bases purely on upfront loaded track data do not comply with intention or rules of DV.

DV 1.4 Remote Emergency System (RES)

DV 1.4.1 Every vehicle must be equipped with a standard RES specified in the competition handbook. The system consists of two parts, the remote control and the vehicle module.

DV 1.4.2 The RES must be purchased by the team.

DV 1.4.3 The RES has two functions:

DV 2 Autonomous System (AS)

- (a) When the remote emergency stop button is pressed, it must trigger the DV shutdown circuit defined in DV 1.5.
- (b) Race-control-to-vehicle communication:
 - (i) The race control can send a “Go” signal to the vehicle
 - (ii) The “Go” signal replaces green flags

- DV 1.4.4 The RES vehicle module must be directly integrated in the vehicle’s shutdown circuit. Directly means hard-wired in series to the shutdown buttons.
- DV 1.4.5 When the vehicle is driving in autonomous mode, one ASR must be present at the race control to operate the RES remote control (see also D 2.2.8 and D 2.7).
- DV 1.4.6 The antenna of the RES must be mounted unobstructed and without interfering parts in proximity (other antennas, etc.).

DV 1.5 Shutdown circuit

- DV 1.5.1 The drivetrain-specific requirements for the shutdown circuit (see CV 4.1 or EV 7) remain valid for DV.
- DV 1.5.2 Triggering the shutdown circuit must have the following responses in addition to the drivetrain-specific behavior:
 - (a) The EBS (see rule DV 3) must be triggered.
 - (b) The autonomous steering system may remain active when the remote emergency stop button is activated.
- DV 1.5.3 If the shutdown circuit is opened by the Autonomous System (AS) or the RES, it has to be latched open by a non-programmable logic that can only be reset via GLVMS power cycle.

DV 2 AUTONOMOUS SYSTEM (AS)

DV 2.1 Signals

- DV 2.1.1 Any signal of the AS is a SCS.

DV 2.2 Autonomous System Master Switch (ASMS)

- DV 2.2.1 Each DV must be equipped with an ASMS, according to T 10.1.
- DV 2.2.2 The ASMS must be mounted in the middle of a completely blue circular area of ≥ 35 mm diameter.
- DV 2.2.3 The ASMS must be marked with “ASMS”.
- DV 2.2.4 The power supply of the steering and braking actuators must be switched by GLVMS and ASMS
- DV 2.2.5 When the ASMS is in “Off” position (i.e. manual mode), the following must be fulfilled:

DV 2 Autonomous System (AS)

- No steering, braking and propulsion actuation can be performed by request of the autonomous system.
- The sensors and the processing units can stay operational.
- The vehicle must be able to be pushed as specified in A 6.7.
- It must be possible to operate the vehicle manually as a normal CV or EV.
- The EBS must not be actuated.

DV 2.2.6 It is strictly forbidden to switch the ASMS to the “On” position if a person is inside the vehicle (for safety there will be no driver in the vehicle when it is in autonomous mode).

DV 2.2.7 The ASMS may only be switched on by the ASR after approval from an official.

DV 2.2.8 After switching the ASMS to the “On” position, the vehicle may not start moving and the brakes must remain closed (“AS ready” state, Figure 19) until a “Go” signal is sent via the RES (“AS driving” state, Figure 19).

DV 2.2.9 The ASMS must be fitted with a “lockout/tagout” capability to prevent accidental activation of the AS. The ASR must ensure that the ASMS is locked in the off position whenever the vehicle is outside the dynamic area or driven in manual mode.

DV 2.3 Autonomous System Status Indicators (ASSIs)

DV 2.3.1 The vehicle must include three ASSIs that must indicate the status of the AS. The ASSIs may not perform any other functions.

DV 2.3.2 The ASSIs must indicate the AS status definitions as defined in DV 2.4.

DV 2.3.3 One ASSI must be located on each side of the vehicle behind the driver’s compartment, in a region 160 mm below the top of the main hoop and 600 mm above the ground. The third ASSI must be located at the rear of the vehicle, on the vehicle centerline, near vertical, and 100 mm above the brake light.

DV 2.3.4 Each ASSI must have a dark, high contrast with yellow background and a rectangular, triangular or near round shape with a minimum shining surface of 15 cm². The ASSIs must be clearly visible in very bright sunlight. When LED lights are used without a diffuser, they may not be more than 20 mm apart. If a single line of LEDs is used, the minimum length is 150 mm. At least one ASSI must be visible from any angle of the vehicle.

DV 2.4 Autonomous State Definitions

DV 2.4.1 The AS must implement the states and state transitions as shown in Figure 19.

DV 2.4.2 The AS must not have any other states or transitions.

DV 2.4.3 A state-transition is initiated by the corresponding action and can only be completed if ALL requirements are fulfilled. Until the transition is complete the ASSIs must indicate the initial state.

DV 2.4.4 The steering actuator can only have the following states:

- “off”: power supply of the actuator is disconnected, manual steering is possible

DV2 Autonomous System (AS)

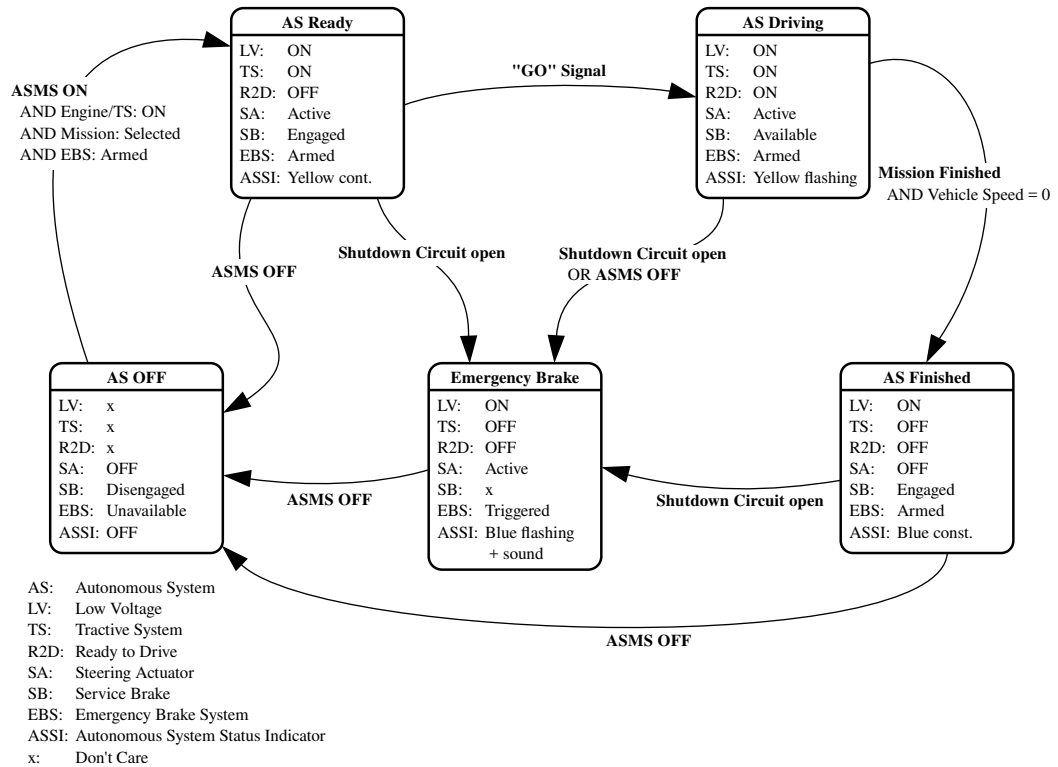

Figure 19: AS state machine

- “active”: responds immediately to commands from the AS

DV 2.4.5 The service brake can only have the following states:

- “disengaged”: power supply of the actuator is disconnected, manual braking is possible
- “engaged”: prevents the vehicle from rolling on a slope up to 15 %
- “available”: responds immediately to commands from the AS

DV 2.4.6 The EBS can only have the following states:

- “unavailable”: the actuator is disconnected from the system/the energy storage is de-energized, emergency brake maneuver is not possible
- “armed”: will initiate an emergency brake maneuver immediately if the shutdown circuit is opened or the GLVS supply is interrupted
- “triggered”: brakes are closed and may be only released after switching ASMS off or performing manual steps

DV 2.4.7 The state “Emergency Brake” has to be indicated by an intermittent sound with the following parameters:

- on-/off-frequency: 1 Hz to 5 Hz
- duty cycle 50 %
- sound level between 80 dBA and 90 dBA, fast weighting.
- duration between 15 s and 20 s after entering “Emergency Brake”

DV 3 Emergency Brake System (EBS)

DV 2.4.8 During the transition to finish state, the EBS must not transit to “triggered” if the shutdown circuit is opened by the AS to switch off the TS. If any other part of the shutdown circuit is opened during the transition to finish state or in finish state, the EBS must be triggered.

DV 2.5 Autonomous Missions

DV 2.5.1 The AS must at least implement the following missions:

- Acceleration
- Skidpad
- Trackdrive
- EBS test
- Inspection

DV 2.5.2 The inspection mission will be used during technical inspection while the vehicle is jacked up and all wheels are removed.

DV 2.5.3 The inspection mission is defined by slowly spinning the drivetrain and actuating the steering system with a sine wave. After 25 s to 30 s the mission is finished and the transition to “AS Finish” must be initialized.

DV 2.5.4 The selected mission must be indicated by the Autonomous Mission Indicator (AMI).

DV 2.5.5 The AMI must be easy readable and can either be part of the dashboard or located next to the ASMS. If an e-ink display is used, it must be visible that the shown mission is up-to-date. AMI is considered SCS!

DV 2.5.6 The AMI will be checked before every dynamic discipline.

DV 2.6 Autonomous System Form (ASF)

DV 2.6.1 Prior to the competition, all teams must submit a clearly structured documentation of their entire AS (including EBS and steering system) called ASF.

DV 2.6.2 The ASF must at least contain the following items:

- All applied sensors (see also DV 4.2)
- A clearly structured documentation of the entire EBS.
- A dbc file defining the supervised signals of the EBS monitoring.
- A clearly structured documentation of the entire steering system.

DV 3 EMERGENCY BRAKE SYSTEM (EBS)

DV 3.1 Technical Requirements

DV 3.1.1 All specifications of the brake system from T5 remain valid.

DV 3 Emergency Brake System (EBS)

- DV 3.1.2 The vehicle must be equipped with an EBS, that is triggered when the shutdown circuit opens using non-programmable logic only (beside monitoring).
- DV 3.1.3 The EBS must only use passive systems with mechanical energy storage. Electrical power-loss at EBS must lead to a direct emergency brake maneuver (keep in mind EV 7.2.2!).
- DV 3.1.4 The EBS may be part of the hydraulic brake system.
- DV 3.1.5 When the EBS is part of the hydraulic brake system, the manual brake actuation (by brake pedal) may be deactivated for autonomous driving.
- DV 3.1.6 The EBS must be designed so that a track marshal can deactivate it (e.g. by turning off the ASMS). For example, this is necessary when the vehicle is shut down by RES and needs to be moved by a track marshal.
- DV 3.1.7 A pictographic description of the necessary steps to release the EBS must be clearly visible in proximity to the ASMS or at the release point. This point must be marked by a red arrow of 100 mm length (shaft width of 20 mm) with “EBS release” in white letters.
- DV 3.1.8 The use of push-in fittings is prohibited in function critical pneumatic circuits of the EBS.

DV 3.2 Functional Safety

- DV 3.2.1 Due to the safety critical character of the EBS, the system must either remain fully functional, or the vehicle must automatically transition to the safe state in case of a single failure mode.
- DV 3.2.2 The safe state is the vehicle at a standstill, brakes engaged to prevent the vehicle from rolling, and an open shutdown circuit.
- DV 3.2.3 To get to the safe state, the vehicle must perform an autonomous brake maneuver described in section DV 3.3 and IN 6.3.
- DV 3.2.4 The tractive system is not considered to be a brake system.
- DV 3.2.5 The service brake system may be used as redundancy if two-way monitoring is ensured.
- DV 3.2.6 A red indicator light in the cockpit that is easily visible even in bright sunlight and clearly marked with the lettering “EBS” must light up if the EBS detects a failure.

DV 3.3 EBS Performance

- DV 3.3.1 The system reaction time (the time between entering the triggered state and the start of the deceleration) must not exceed 200 ms.
- DV 3.3.2 The average deceleration must be greater than 8 m/s^2 under dry track conditions.
- DV 3.3.3 Whilst decelerating, the vehicle must remain in a stable driving condition (i.e. no unintended yaw movement). This can be either a controlled deceleration (steering and braking control is active) or a stable braking in a straight line with all four wheels locked.
- DV 3.3.4 The performance of the system will be tested at technical inspection, see IN 6.3.

DV 4 SENSORS

DV4.1 Mounting

- DV 4.1.1 All sensors must be securely mounted. For all sensor mounts, T7.4.1 applies.
- DV 4.1.2 Sensors may not come into contact with the driver's helmet under any circumstances.
- DV 4.1.3 All sensors must be positioned within the surface defined by the top of the main hoop and the outside edges of the four tires (see figure 20).
- DV 4.1.4 Additionally, sensors may be mounted with a maximum distance of 500 mm above the ground and less than 700 mm forward of the front of the front tires (see Figure 20). They must not exceed the width of the front axle (measured at the height of the hubs).

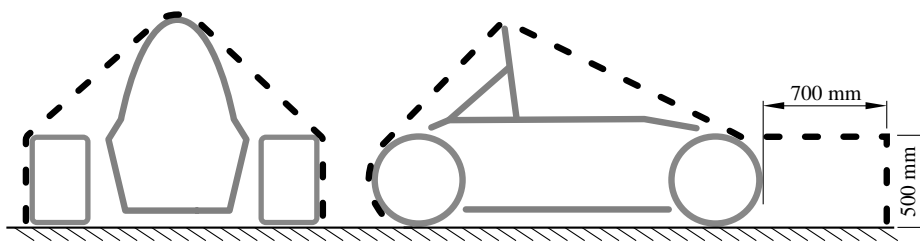

Figure 20: Envelope to mount sensor systems.

DV4.2 Legal & Work Safety

- DV 4.2.1 All sensors must fulfill the local legislative specifications (i.e. eye-protection classification for laser sensors, power limitation for radar sensors, etc.) in the country of competition.
- DV 4.2.2 This must be demonstrated by submitting the datasheets for the implemented sensors prior to the competition as an ASF Add Item Request (AAIR).

IN TECHNICAL INSPECTIONS

IN 1 GENERAL

IN 1.1 Technical Inspection Objective

IN 1.1.1 The technical inspections are to determine if the vehicle is able to participate in the dynamic events and is compliant to the rules.

IN 1.2 Technical Inspection Process

IN 1.2.1 The technical inspection is divided into the following parts:

- Pre-Inspection
- [EV ONLY] Accumulator Inspection
- [EV ONLY] Electrical Inspection
- Mechanical Inspection
- [DV ONLY] Driverless Inspection
- Tilt Test
- Vehicle Weighing
- [CV ONLY] Noise Test
- [EV ONLY] Rain Test
- Brake Test
- [DV ONLY] EBS Test

IN 1.3 General Rules

IN 1.3.1 Each vehicle must pass all parts of technical inspection before it may participate in any dynamic event.

IN 1.3.2 Passing the technical inspections is not a certification of complete rules compliance of the vehicle.

IN 1.3.3 The technical inspection sheet includes all inspection points and will be provided on the competition website prior to the competition. It must always stay with the vehicle.

IN 1.3.4 The officials may inspect other points not mentioned on the technical inspection sheet to ensure compliance with the rules.

IN1 General

- IN1.3.5 Teams are responsible for confirming that their vehicle and the required equipment satisfies the requirements and restrictions of the rules before presenting it for technical inspection.
- IN1.3.6 Vehicles must be presented for technical inspection in ready-to-race condition.
- IN1.3.7 All items on the inspection sheet must be clearly visible for the officials without using instruments such as endoscopes or mirrors. Visible access may be provided by removing body panels or by providing removable access panels.
- IN1.3.8 The vehicle must maintain all required specifications throughout the competition.
- IN1.3.9 Officials will mark or seal various different approved parts. Removal of or damage to the seals will void the inspection approval.
- IN1.3.10 Once the vehicle is approved for competition, any damage to the vehicle that requires repair(s) will void the inspection approval. After completion of the repair(s), the vehicle must be re-submitted to technical inspection for re-approval.
- IN1.3.11 Each team must present a quick jack to lift up the vehicle during technical inspection, see T12.2.
- IN1.3.12 A maximum of four team members may enter the inspection area at one time.

IN1.4 Technical Inspection Sticker

- IN1.4.1 The competition technical inspection stickers will be placed on the nose of the vehicle.
- IN1.4.2 If a vehicle is no longer in compliance with the rules, the officials will set the vehicle's technical inspection status to fail, remove the respective inspection sticker(s) from the vehicle and note the reason for revoking the technical inspection approval in the technical inspection sheet.

IN1.5 Inspection Responsible Person

- IN1.5.1 To accelerate the technical inspection process, the team must appoint one team member as inspection responsible person. [EV ONLY] For electrical inspection and accumulator inspection this has to be an ESO.
- IN1.5.2 This inspection responsible person must be:
- Familiar with the vehicle.
 - Able to show compliance of the vehicle with all points mentioned on the technical inspection sheet.
 - Able to perform the technical inspection autonomously observed by the officials, when asked.
- IN1.5.3 Should the inspection responsible person be unable to perform one of these requirements, or the vehicle and all necessary items are not ready, the technical inspection will be aborted and the team will be asked to leave the technical inspection area.

IN2 Pre-Inspection

IN 1.6 Modifications and Repairs

IN 1.6.1 After technical inspection, the only modifications permitted to the vehicle are:

- Adjustment of belts, chains and clutches
- Adjustment of the brake bias
- Adjustment of the driver restraint system, head restraint, seat and pedal assembly
- Substitution of the head restraint or seat insert for different drivers
- Adjustment to engine operating parameters, e.g. fuel mixture and ignition timing
- Adjustment of mirrors
- Adjustment of the suspension where no part substitution, other than springs, sway bars and shims, is required
- Adjustment of tire pressure
- Adjustment of winglet angles, but not the position of the complete aerodynamic device in relation to the vehicle
- Replenishment of fluids
- Replacement of defective tires or brake pads. Replacement tires and brake pads must be identical in material/composition/size to those presented and approved at technical inspection.
- Changing wheels and tires for “wet” or “damp” conditions as allowed in D3.2 and D7.5
- Software calibration changes
- Recharging low voltage batteries
- Recharging TS accumulators
- [DV ONLY] Adjustments of sensors

IN 2 PRE-INSPECTION

IN 2.1 Pre-Inspection Objective

IN 2.1.1 At pre-inspection components and driver’s equipment are checked for compliance with the rules.

IN 2.2 Pre-Inspection Required Items

IN 2.2.1 The following items must be presented for pre-inspection:

- All helmets
- All driver’s equipment and other safety gear
- Two sets of four tires mounted on rims for dry and wet driving conditions
- Two unused and in date fire extinguishers

IN3 [EV ONLY] ACCUMULATOR INSPECTION

IN3.1 Accumulator Inspection Objective

IN3.1.1 At the accumulator inspection the accumulator charger, the accumulator container and its internal parts are checked for compliance with the rules.

Cell modules or stacks do not need to be disassembled when AIRs, fuses, pre- and discharge circuit and positive locking mechanism of the maintenance plugs are reachable and visible for the officials.

IN3.1.2 An official temperature logging device must be installed, see EV 6.8.5.

IN3.1.3 The accumulator charger will be inspected and sealed.

IN3.1.4 The set of basic tools will be checked.

IN3.2 Accumulator Inspection Required Items

IN3.2.1 The following items must be presented at accumulator inspection:

- All TS accumulators
- Accumulator hand cart
- Accumulator charger
- Basic Tools, see IN 3.2.2
- Tools needed for the (dis)assembly of parts
- Data sheets for all parts used in the accumulator
- Print-outs of rule questions (if applicable)

IN3.2.2 The following basic tools in good condition must be presented:

- Insulated cable shears
- Insulated screw drivers
- Multimeter with protected probe tips
- Insulated tools, if screwed connections are used in the tractive system
- Face shield
- at least two pairs of HV insulating gloves (not expired)
- Two HV insulating blankets of at least 1.0 m² each
- Safety glasses with side shields for all team members that might work on the tractive system or accumulator

All electrical safety items must be rated for at least the maximum tractive system voltage.

IN4 [EV ONLY] Electrical Inspection

IN 4 [EV ONLY] ELECTRICAL INSPECTION

IN4.1 Electrical Inspection Objective

IN4.1.1 During the electrical inspection, all electrical parts and systems of the vehicle are checked for compliance with the rules.

IN4.1.2 The insulation resistance between the tractive system and GLVS ground will be measured. Vehicles with a maximum tractive system voltage less than or equal to 250 V will be probed with 250 V and vehicles with a maximum tractive system voltage greater than 250 V with 500 V.

To pass this test, the measured insulation resistance must be at least $500 \Omega/v$ related to the maximum tractive system voltage of the vehicle.

IN4.1.3 The IMD will be tested by connecting a resistor between the tractive system measuring points, see EV 5.7, of the tractive system and GLVS ground connector, see EV 5.7.7.

The test is passed if the IMD shuts down the tractive system within 30 s at a fault resistance of 50 % below the response value which corresponds to $250 \Omega/v$.

IN4.2 Electrical Inspection Required Items

IN4.2.1 The following items must be presented at electrical inspection:

- One ESO
- Vehicle with mounted TS accumulator
- Quick jack and push bar
- Samples of self designed PCBs that are part of the tractive system
- Tools needed for the BSPD check, see EV 7.5.8
- Data sheets for all parts used in the tractive system
- Tools needed for the (dis)assembly of parts for electrical inspection
- Print-outs of rule questions (if applicable)

IN 5 MECHANICAL INSPECTION

IN5.1 Mechanical Inspection Objective

IN5.1.1 During the mechanical inspection, all mechanical parts of the vehicle are checked for compliance with the rules.

IN5.2 Mechanical Inspection Tire and Rim Combination

IN5.2.1 Each team must present one set of tires for dry conditions and one set of tires for wet conditions mounted on rims.

IN6 [DV ONLY] Driverless Inspection

IN5.2.2 The tire type/rim type combination presented during technical inspection must be the same during the whole competition. The rims for dry tires and wet tires may be different.

IN5.3 Mechanical Inspection Required Items

IN5.3.1 The following items must be presented at mechanical inspection:

- The vehicle
- Quick jack and push bar
- The tallest driver of the team
- Copies of any safety structure equivalency forms
- Copies of any impact attenuator data requirement
- Print-outs of rule questions (if applicable)
- Impact attenuator test piece (except for teams with “standard” IA)
- Teams with a monocoque: laminate test specimen(s)
- Only tools needed for the (dis)assembly of parts for mechanical inspection
- Set of tires on rims for wet conditions
- Set of tires on rims for dry conditions

IN6 [DV ONLY] DRIVERLESS INSPECTION

IN6.1 Driverless Inspection Objective

IN6.1.1 The objective of the DV inspection is to prove that:

- All implemented sensors, including their mounting and location, are compliant with the rules.
- RES, ASMS, EBS, ASSI and the datalogging system are working as specified.

IN6.2 Driverless Inspection Required Items

IN6.2.1 The following items are required:

- One ASR
- The vehicle (in fully assembled , ready-to-race condition including mounted datalogger (see DV 1.3)
- Data sheets for all perception sensors
- Documents which proof that all perception sensors meet local legislation
- RES remote control
- ASF
- Tools needed for the (dis)assembly of parts for DV inspection
- Print-outs of rule questions (if applicable)

IN7 Tilt Test

IN6.3 Driverless Inspection EBS Test

- IN6.3.1 The EBS performance will be tested dynamically and must demonstrate the performance described in DV 3.3.
- IN6.3.2 The test will be performed in a straight line marked with cones similar to acceleration.
- IN6.3.3 During the brake test, the vehicle must accelerate in autonomous mode up to at least 40 km/h within 20 m. From the point where the RES is triggered, the vehicle must come to a safe stop within a maximum distance of 10 m.
- IN6.3.4 In case of wet track conditions, the stopping distance will be scaled by the officials dependent on the friction level of the track.

IN 7 TILT TEST

IN7.1 Tilt Test Objective

- IN7.1.1 The tilt test is to evaluate the rollover stability of the vehicle and to check for any fluid leaks.

IN7.2 Tilt Test Procedure

- IN7.2.1 The tilt test will be conducted with the tallest driver fully strapped in normal driving position.
- IN7.2.2 The tilt test will be conducted with all vehicle fluids at their maximum fill level.
- IN7.2.3 The vehicle will be placed upon the tilt table and to an angle of 45°. There must be no fluid leaks.
- IN7.2.4 If the vehicle passes IN7.2.3, the angle is increased to 60° representing a cornering force of 1.7 g. All wheels must remain in contact with the tilt table surface at this angle.

IN 8 VEHICLE WEIGHING

IN8.1 Vehicle Weighing Objective

- IN8.1.1 At the vehicle weighing, the vehicle's official technical inspection weight is determined.

IN8.2 Vehicle Weighing Procedure

- IN8.2.1 All vehicles must be weighed in ready-to-race condition.
- IN8.2.2 All fluids must be at their maximum fill level for weighing.

IN9 [EV ONLY] Rain Test

IN9 [EV ONLY] RAIN TEST

IN9.1 Rain Test Objective and General Definitions

- IN9.1.1 The rain test checks for protection of the electrical system from moisture in the form of rain or puddles.
- IN9.1.2 Vehicles must have passed electrical inspection, see IN4, to attempt the rain test.

IN9.2 Rain Test Procedure

- IN9.2.1 The vehicle must be in ready-to-race condition. All components and constructions used to protect the vehicle from water during the rain test must be used during the entire competition.
- IN9.2.2 The tractive system must be active during the rain test.
- IN9.2.3 The vehicle must be jacked up using the quick jack (see T 12.2) and all four wheels must be removed.
- IN9.2.4 The vehicle must not be in ready-to-drive mode, see EV 5.11.
- IN9.2.5 The test will be conducted without a driver.
- IN9.2.6 Water will be sprayed at the vehicle from any possible direction. The water spray is similar to rain and not a direct high-pressure stream of water.
- IN9.2.7 The test is passed if the IMD is not triggered while water is sprayed at the vehicle for 120 s and 120 s after the water spray has stopped.

IN10 [CV ONLY] NOISE TEST

IN10.1 Noise Test Objective

- IN10.1.1 The vehicle will be checked for compliance with the sound level restrictions, see CV 3.2.

IN10.2 Noise Test Procedure

- IN10.2.1 The sound level will be measured during a static test.
- IN10.2.2 The vehicle must be compliant at all engine speeds up to the maximum test speed, see CV 3.2.1.
- IN10.2.3 Teams must bring a laptop to indicate the engine speed measured by the ECU.
- IN10.2.4 Measurements will be made with a free-field microphone placed free from obstructions at the exhaust outlet level, 0.5 m from the end of the exhaust outlet, at an angle of 45° with the outlet in the horizontal plane.
- IN10.2.5 Where more than one exhaust outlet is present, the test will be repeated for each exhaust and the highest reading will be used.

IN11 Brake Test

- IN10.2.6 If the exhaust has any form of active tuning or throttling device or system, it must be compliant with the rules in all positions. Manually adjustable tuning devices must require tools to change them and must not be moved or modified after the noise test is passed. The position of the device must be visible to the officials and manually operable by the officials during the noise test.
- IN10.2.7 The test will be run with the gearbox in neutral. During this test the vehicle must be jacked up using the quick jack (see T 12.2).
- IN10.2.8 After passing the noise test the function of the master switch and cockpit-mounted shutdown button will be tested.
- IN10.2.9 After passing IN 10.2.8 the air tightness of the intake system will be tested by closing off the inlet after which the engine must stall.
- IN10.2.10 If the vehicle is unable to pass after three attempts, the vehicle must be repaired and then brought back for a retest.

IN 11 BRAKE TEST

IN11.1 Brake Test Objective

- IN11.1.1 The brake system will be dynamically tested and must demonstrate the capability of locking all four wheels and stopping the vehicle in a straight line.

IN11.2 Brake Test Procedure

- IN11.2.1 Lock all four wheels and stop the vehicle in a straight line at the end of an acceleration run specified by the officials without stalling the engine.
- IN11.2.2 [EV ONLY] After accelerating, the tractive system must be switched off by the driver and the driver must brake using only the mechanical brakes. It is acceptable for the TSAL to switch to green shortly after the vehicle has come to a complete stop as the reduction of the system voltage may take up to 5 s.
- IN11.2.3 The brake light and TSAL illumination will be checked and the officials will verify if the illumination is satisfactory for external observation.
- IN11.2.4 [EV ONLY] The ready-to-drive sound will be checked and the officials will verify if the sound level is satisfactory.
- IN11.2.5 If the vehicle is unable to pass the test after three attempts, the vehicle must be repaired and then brought back for retesting.
- IN11.2.6 [DV ONLY] The EBS test (see IN6.3) is conducted after all other elements of IN 11 have been passed.

IN 12 POST EVENT INSPECTION

IN12.1 Post Event Inspection Objective

IN12 Post Event Inspection

IN12.1.1 The officials reserve the right to impound any vehicle at any time during or after any of the dynamic events to check for compliance with the rules. If necessary the vehicle will remain with the officials until the violation of the rule was discussed with the team.

IN 12.2 Post Event Inspection Procedure

IN 12.2.1 After the endurance event, the vehicle must be placed in parc fermé where no team member may access the vehicle.

IN 12.2.2 After any dynamic event, the vehicle must be in compliance with the rules.

IN 12.2.3 For each violation of the rules, the team receives a separate penalty as follows:

- Group A: Violation of the rules without advantage for the team
- Group B: Violation of the rules with advantage for the team (e.g. aerodynamic device)

	Acceleration	Skidpad	Autocross	Endurance	Trackdrive
Group A	0.3 s	0.3 s	1 s	30 s	30 s
Group B	1 s	1 s	5 s	2 min	2 min

IN 12.2.4 Violation of the rules concerning safety or the environment (e.g. BOTS, safety harness issues, ground clearance, fluid leaks, noise) results in a Did Not Finish (DNF) for that particular run.

IN 12.2.5 Changes in vehicle weight of more than ± 5 kg compared to the official technical inspection weight (see IN 8) results in a 20 point penalty for each kg the tolerance is exceeded by. E.g. a weight difference of ± 6.2 kg results in a 40 point penalty.

IN 12.2.6 [EV ONLY] The vehicle must be able to enter ready-to-drive mode, see EV 5.11, during post inspection process for all tests requiring this mode. Violation will result in DNF.

IN 12.2.7 [EV ONLY] Directly after endurance and leaving parc fermé, every team must come back to the charging area to disassemble the temperature logging device from the TS accumulator (see EV 6.8.5).

IN 12.2.8 [EV OR DV ONLY] Directly after trackdrive or endurance and leaving parc fermé, the data logger, see EV 5.6 or DV 1.3, will be disassembled from the vehicle.

S STATIC EVENTS

S 1 BUSINESS PLAN PRESENTATION EVENT (BPP)

S 1.1 Business Plan Presentation Objective

- S 1.1.1 The objective of the BPP is to evaluate the team's ability to develop and deliver a comprehensive business model which demonstrates their product – a prototype race car – could become a rewarding business opportunity.
- S 1.1.2 The judges should be treated as if they were potential investors or partners for the presented business model.
- S 1.1.3 The business plan must relate to the specific prototype race car entered in the competition. The quality of the actual prototype will not be considered as part of the BPP judging.

S 1.2 Business Plan Presentation Procedure

- S 1.2.1 Presentations are limited to a maximum of ten minutes. The judges will stop any presentation exceeding ten minutes.
- S 1.2.2 The presentation will not be interrupted by questions. Immediately following the presentation there will be a question and answer session.
- S 1.2.3 One or more team members may present the business plan.
- S 1.2.4 All team members involved in the BPP must be in the podium area and must be introduced to the judges at the beginning of the presentation. The team members who have been introduced may answer the judges' questions even if they were not actually presenting.
- S 1.2.5 Data projectors or screens with VGA and HDMI (type A) input connectors will be provided for video signal transmission. Teams planning to use audio or other presentation equipment are responsible for bringing it themselves.
- S 1.2.6 Teams that fail to make their presentation within their assigned time period will receive zero points for the BPP.
- S 1.2.7 Prior to the competition a specific deep dive topic, which has to be part of the ten minute presentation, will be published on the competition website.

S 1.3 Executive Summary

- S 1.3.1 To convince the potential investors or partners that the team's presentation is worthy of their time, it is required that an executive summary is submitted before the competition. The executive summary should contain a brief description of the team's business plan.

S2 Cost and Manufacturing Event

- S1.3.2 The executive summary must not exceed one page. The vehicle number and university name must be written in the top right corner.
- S1.3.3 The executive summary must be submitted online via the competition website, not later than the deadline specified in the competition handbook.
- S1.3.4 If the executive summary is not compliant with the rules, 5 penalty points are deducted from the final BPP score.

S1.4 Business Plan Presentation Scoring

- S1.4.1 The BPP will be evaluated on the categories specified in the following table:

Category	Points
Executive Summary	10
Novelty	10
Content	20
Finances	10
Deep Dive Topic	10
Demonstration and Structure	15
Delivery	10
Questions	10
General Impression	5
Total	100

- S1.4.2 The judging at the competition will start with an initial judging, where all teams are judged by different judging groups. The top three to five teams are then judged by all business judges in the BPP finals.
- S1.4.3 The scoring of the BPP is based on the average of the scores given by each of the judges.
- S1.4.4 The scoring for the non-finalist is calculated as followed:

$$BPPSCORE = 70 \left(\frac{P_{team}}{P_{max}} \right)$$

P_{team} is the score awarded to the team

P_{max} is the highest score awarded to any team not participating in the finals

- S1.4.5 The scoring of the BPP finalists will vary from 75 to 71 points and is scored immediately after the BPP finals by all judges.

S2 COST AND MANUFACTURING EVENT

S2.1 Cost and Manufacturing Objective

- S2.1.1 The objective of the cost and manufacturing event is to evaluate the team's understanding of the manufacturing processes and costs associated with the construction of a prototype race car. This includes trade off decisions between content and cost, make or buy decisions and understanding the differences between prototype and mass production.

S2 Cost and Manufacturing Event

S2.2 Cost and Manufacturing Procedure

- S2.2.1 Prior to the competition, three CRD (see S2.3) must be submitted to the competition website by the deadline specified in the competition handbook.
- S2.2.2 During the competition, a discussion with the judges will take place, next to the team's vehicle. The discussion is split into two parts:
- S2.2.3 Part 1 "Bill of Material (BOM) Discussion":
A discussion to evaluate the team's ability to prepare an accurate engineering and manufacturing BOM for the complete vehicle. The team must prove the following:
- The specification of the vehicle in the CRD accurately reflects the vehicle brought to the competition.
 - The costs within the Costed Bill of Material (CBOM) part of the BOM are correct and realistic.
 - The manufacturing feasibility of the vehicle.
- S2.2.4 Part 2 "Cost Understanding":
A discussion to evaluate the general cost and manufacturing knowledge of the team. The following topics might be judged:
- Differences between prototype and mass production
 - Resource and cost planning
 - Financial and production risk management
 - Make or buy decisions
 - Environmental influence of the vehicle production
 - Effectiveness of financial planning
- S2.2.5 The teams must present their vehicle at the designated time to the judges. Teams that miss their time slot will lose all cost points for that day.
- S2.2.6 Teams are allowed to bring electronic, handwritten, or printed handouts, flip charts or similar to the event, but the space available may be limited.
- S2.2.7 If the team takes too long, blocks the bay or does not show up on-time, five penalty points will be deducted from the team's cost event score.

S2.3 Cost Report Documents (CRD)

- S2.3.1 The CRD consist of the following documents:
- The BOM created online on the competition website
 - The supporting material file uploaded as a pdf file to the competition website
 - The cost explanation file uploaded as a pdf file to the competition website
- S2.3.2 An addendum for the CRD is not possible and changes will not be permitted after the deadline.

S2 Cost and Manufacturing Event

- S2.3.3 All CRD documents must be brought as one hard copy and one digital version, two hard copies or a splittable folder of the CRD to the event discussion.
- S2.3.4 The website tool will provide a printable pdf version of the BOM.
- S2.3.5 The hard copy must be in a ring binder with DIN A4 pages (or similar).
- S2.3.6 The hard copy must be identical to the uploaded version, otherwise five penalty points will be deducted from the team's cost event score.

S2.4 Bill of Material (BOM)

- S2.4.1 The BOM is a sorted list for every vehicle part including the associated manufacturing processes.
- S2.4.2 The BOM must:
- List all parts and equipment fitted to the prototype vehicle at any time during the competition.
 - Be based on the actual manufacturing processes used for the prototype.
 - Include tooling (e.g. welding jigs, molds, patterns and dies).
 - Not include any cost, except for the "systems" described in S2.5.
- S2.4.3 The BOM is structured as follows:
- The BOM is broken down into "systems" (see S2.4.4), which are defined by the website tool.
 - Each "system" is broken down into "assemblies", which are defined by the website tool.
 - Each "assembly" is broken down into "parts", which must be defined by the team.
 - Each "part" is broken down into "materials" and "processes".
 - Each "process" may be broken down into "tooling" and "fasteners", if applicable.
- S2.4.4 The "systems" are:
- Brake System
 - Engine and Drivetrain
 - Chassis and Body
 - Electrical
 - Miscellaneous, Fit and Finish
 - Steering System
 - Suspension System
 - Wheels, Wheel Bearings and Tires
 - [DV ONLY] Autonomous system
- S2.4.5 The "assemblies" of each "system" are provided by the website tool.

S2 Cost and Manufacturing Event

- S2.4.6 When adding “parts” to the BOM, the comments section should be reviewed thoroughly. The chosen part name must clearly describe what is included. For example, if a spring is included, the “part” should not be called “damper”.
- S2.4.7 Each constituent “part” of an “assembly” must be classified as “bought” or “made”.
- S2.4.8 For each “bought part”, only fasteners must be included (if required). If the part was modified, the associated processes for this modification must to be included.
- S2.4.9 For each “made part” the raw material, all production processes, tooling and all required fasteners must be included.
- S2.4.10 “Processes” are the necessary operations to produce the “part” out of the “material”.
- S2.4.11 “Material” is the raw material of a part, eg. aluminium.
- S2.4.12 “Tooling” is the necessary tools used for transforming the “material” into the desired shape.
- S2.4.13 “Fasteners” are additional items necessary to assemble the “part”.
- S2.4.14 Only metric units must be used within the BOM.
- S2.4.15 Only dry tires and wheels per T 1.5.1 need to be included and must be mounted on the vehicle during judging.
- S2.4.16 One or two systems of the BOM have to be a CBOM, see S2.5.

S2.5 Costed Bill of Material (CBOM)

- S2.5.1 The actual costs of the prototype vehicle as presented must be included for one or two BOM system(s) specified in the competition handbook.
- S2.5.2 The cost calculations must include the costs of materials, fabrication, bought parts and assembly to the vehicle and must be completed as realistically as possible.
- S2.5.3 The cost calculations must exclude research, development and capital expenditures for real estates (e.g. plant or development hours of the team).
- S2.5.4 All costs must be displayed in EUR. For calculating the prices in EUR from other currencies, the team must provide the exchange rates used.
- S2.5.5 There is no maximum cost. Receipts are not required for any items.
- S2.5.6 If production tooling is associated with processes that are specific to the part geometry, it must be included. For example the dies to stamp out a chassis bracket are tooling.
- S2.5.7 The costs of hand or power tools must not be included.
- S2.5.8 The estimations for machining rates, hourly rates, included overheads etc. must be shown.

S2.6 Supporting Material File

- S2.6.1 The supporting material file is a document containing additional information which allows the judges to understand the BOM. It should include drawings, exploded view drawings and/or pictures of the vehicle and the parts included in the BOM.

S3 Engineering Design Event

S2.7 Cost Explanation File

- S2.7.1 The cost explanation file is a document containing additional explanations, which allow the judges to understand the costs within the CBOM part of the BOM.
- S2.7.2 The cost explanation file should point out which cost model was used and which types of costs are included. It should also contain which specific cost figures were used, e.g. the cost of one machine operation hour.

S2.8 Cost and Manufacturing Vehicle Condition

- S2.8.1 Vehicles must be presented for cost and manufacturing judging in finished condition, fully assembled, complete, ready-to-race and with its dry tires (see T 1.5.1) mounted.
- S2.8.2 The judges will not evaluate any vehicle that is presented at the cost and manufacturing event, in what they consider to be an unfinished state and will award zero points for the entire event.
- S2.8.3 Vehicles may be presented for judging without having passed technical inspection, even if final tuning and setup is in progress.
- S2.8.4 Covers and/or parts may be removed during the judging to facilitate access and presentation of components or concepts.

S2.9 Cost and Manufacturing Scoring

- S2.9.1 The following maximum scores apply for the cost and manufacturing event:

Category	Points
Format and Accuracy of Documents	5
Knowledge of Documents and Vehicle	5
Content and Completeness of the BOM	20
Realism of the CBOM	20
Discussion Part 2 “Cost Understanding”	50
Total	100

- S2.9.2 If items are missing from the BOM, points are deducted until zero points are scored for “Content and Completeness of the BOM”:

Missing Item	Points
Assembly	–5
Part	–3
Process/Material	–1

S3 ENGINEERING DESIGN EVENT

S3.1 Engineering Design Objective

- S3.1.1 The concept of the design event is to evaluate the student’s engineering process and effort that went into the design of a vehicle, meeting the intent of the competition.

S3 Engineering Design Event

S3.1.2 Proprietary components and systems that are incorporated into the vehicle design as finished items are not evaluated as a student designed unit, but are only assessed on the team's selection and application of that unit.

S3.1.3 [DV ONLY] For DV teams an evaluation concerning the capability of the vehicle to drive autonomously will also be part of this event. Therefore, all systems that are required to drive autonomously will be investigated. This also includes a discussion about the hardware and the software used in the AS.

S3.2 Engineering Design Report (EDR)

S3.2.1 The EDR should contain a brief description of the overall vehicle with a review and derivation of the team's design objectives. Any information to scope, explain or highlight design features, concepts, methods or objectives to express the value and performance of the vehicle to the judges shall be included at the teams' discretion.

S3.2.2 The EDR must not exceed eight pages, consisting of not more than five pages of content (text, which may include pictures and graphs) and three pages of drawings.

S3.2.3 The three EDR drawings (no renderings) must show the vehicle from the front, the top and the side. Each drawing must appear on a separate page.

S3.2.4 Any measures to facilitate reviewing the drawings (e.g. measurements, details, colors) may be utilized at the teams' discretion.

S3.2.5 Any portions of the EDR that exceed five pages of content and/or three pages of drawings will not be evaluated.

S3.2.6 If included, cover sheets and tables of contents will count as text pages.

S3.2.7 The EDR will be used to sort the teams into appropriate design queues based on the quality of its review.

S3.2.8 Evidence of information mentioned in the EDR should be brought to the competition and be available, on request, for review by the judges.

S3.3 Design Spec Sheet (DSS)

S3.3.1 A completed DSS must be submitted online on the competition website.

S3.4 [DV ONLY] Autonomous Design Report (ADR)

S3.4.1 The ADR will be used to sort the teams into appropriate design queues, based on the quality of its review.

S3.4.2 The ADR should contain a description of the autonomous system with a review and derivation of the team's design objectives. Any information to scope, explain or highlight design features, concepts, methods or objectives to express the value and performance of the autonomous system to the judges shall be included at the team's discretion.

S3 Engineering Design Event

- S3.4.3 Evidence of information mentioned in the ADR should be brought to the competition and be available, on request, for review by the judges.
- S3.4.4 The ADR must not exceed five pages of content (text, which may include pictures and graphs).
- S3.4.5 Any portions of the ADR that exceed five pages of content will not be evaluated.
- S3.4.6 The ADR must be written as a scientific paper.

S3.5 Engineering Design Procedure

- S3.5.1 The design event starts with the submission of the DSS, the EDR, and [DV ONLY] the ADR and their review respectively.
- S3.5.2 At the competition, teams will present their knowledge and their vehicle to the judges, which will evaluate the teams' performance following the design objectives stated in chapter S3.1.
- S3.5.3 Some teams may be chosen to participate in the design finals to determine the engineering design event winner. The design finals will be held separately from the initial judging and teams will be informed about their participation during the event.
- S3.5.4 Teams may bring any photographs, drawings, charts, spare parts or other material that they believe are supportive to the design event, but the space provided for design judging may be limited.
- S3.5.5 [DV ONLY] Teams need to show some simulation test data, where the judges can see how the algorithms work. During the final, there might be videos and data from the dynamic events. Based on the data, the movements and decisions of the vehicle are discussed. Therefore, the software and the algorithms of the vehicle are investigated in detail.

S3.6 Engineering Design Vehicle Condition

- S3.6.1 Vehicles must be presented for design judging in finished condition, fully assembled, complete and ready-to-race.
- S3.6.2 The judges will not evaluate any vehicle that is presented at the design event in what they consider to be an unfinished state and will award zero points for the entire design event.
- S3.6.3 Vehicles may be presented for design judging without having passed technical inspection, even if final tuning and setup is in progress.
- S3.6.4 Covers and/or parts may be removed during the design judging to facilitate access and presentation of components or concepts.

S3.7 Engineering Design Judging Criteria

- S3.7.1 The judges will evaluate the engineering effort based upon the team's DSS, EDR, and [DV ONLY] ADR, responses to questions and an inspection of the vehicle.
- S3.7.2 The judges will inspect the vehicle to determine if the design concepts are adequate and appropriate for the application (relative to the objectives set forth in the rules).

S3 Engineering Design Event

S3.7.3 The judges may deduct points if the team cannot adequately explain the engineering and construction of the vehicle.

S3.8 Engineering Design Scoring

S3.8.1 The overall engineering design event maximum scoring is 150 points for CV/EV and 325 points for DV.

S3.8.2 The maximum scores listed in Table 5 apply for the engineering design event.

Category	Points	Total
Overall Vehicle Concept	25	
Vehicle Performance	35	
Mechanical / Structural Engineering	25	
Drivetrain	35	150
LV-Electrics / Electronic	10	
Driver Interface / [DV ONLY] AS Actuators	15	
Engineering Design Report (EDR)	5	
Hardware Development	15	
Software Development	15	
Planning	20	
Localization & Mapping	20	
Sensor Data Interpretation	20	175
Safety & Security	15	
Vehicle Networking / Data Processing	15	
Validation, Simulation & Testing	15	
Autonomous Design Report (ADR)	25	
Data Visualization / Usage of Tools	15	

Table 5: Maximum scores in engineering design event (including DV)

D DYNAMIC EVENT REGULATIONS

D1 DYNAMIC EVENTS GENERAL

D1.1 Driver Limitations

- D 1.1.1 In total, a minimum of four and a maximum of six drivers are allowed for each team.
- D 1.1.2 An individual driver may not drive in more than two dynamic events.
- D 1.1.3 The endurance and efficiency event is considered a single event.
- D 1.1.4 [DV ONLY] DV teams need to register at least one driver for manual brake test but may register up to three drivers for testing in manual mode.

D1.2 Dynamic Area and Dynamic Vests

- D 1.2.1 The technical inspections and all dynamic events are held in the dynamic area.
- D 1.2.2 Four dynamic vests are handed out to each team by the officials and must be worn in the dynamic area.
- D 1.2.3 Only four members per team, including the driver, may enter the dynamic area.
- D 1.2.4 Drivers must not wear the dynamic vest when sitting in the vehicle. The driver's vest must not be attached to the vehicle.
- D 1.2.5 The number of tools that may be used in this area is restricted to those which can be safely carried by the four team members in one trip.
- D 1.2.6 Engines may be run in the staging queue on the order of the officials.

D2 DRIVING RULES

D2.1 Flags

- D 2.1.1 Flag signals are commands that must be obeyed immediately and without question.
- D 2.1.2 [DV ONLY] There will be no flag signs for DV in autonomous mode.
- D 2.1.3 **BLACK FLAG** – The driver must pull into the driver change area for discussion with the officials concerning an incident. A time penalty may be assessed.
- D 2.1.4 **BLACK FLAG WITH ORANGE DOT** – Mechanical black flag. The driver must pull into the driver change area for a mechanical inspection of the vehicle, something has been observed that requires a closer inspection.

D2 Driving Rules

- D2.1.5 BLUE FLAG – The driver must pull into the designated passing zone to be passed by a faster competitor. The driver must obey the track marshals signals at the end of the passing zone.
- D2.1.6 CHECKERED FLAG – The session has been completed. The driver must exit the course at the first opportunity.
- D2.1.7 GREEN FLAG –
- (a) The session has started, the driver may enter the course under direction of the track marshals. In case of stalling, the vehicle can be restarted, but the driver has to await another green flag as the opening in traffic may have closed.
 - (b) The driver is clear to re-enter the track after using the slow lane to let a faster vehicle pass.
 - (c) The driver may pick up speed again after a yellow flag was displayed.
- D2.1.8 RED FLAG – The driver must come to an immediate safe and controlled stop on the course and must follow track marshals directions.
- D2.1.9 YELLOW FLAG – Danger, the driver must slow down, something has happened beyond the flag station, no overtaking unless directed by the track marshals.
- D2.1.10 RED AND YELLOW STRIPED FLAG – The track is slippery or something is on the racing surface that should not be there. The driver must be prepared for evasive maneuvers to avoid the situation.

D2.2 Driving Under Power

- D2.2.1 During driving, the mechanical integrity of the vehicle must be maintained.
- D2.2.2 Vehicles must not be driven in reverse.
- D2.2.3 The vehicle must be capable of starting and restarting without external assistance/batteries at all times.
- D2.2.4 Push starts are prohibited.
- D2.2.5 Vehicles may only be driven under power when running in a dynamic event, on the practice track and during brake test.
- D2.2.6 Driving off-site is absolutely prohibited. Teams found to have driven their vehicle at an off-site location during the period of the competition will be excluded from the competition.
- D2.2.7 Burnouts prior to and during the events are prohibited.
- D2.2.8 [DV ONLY] When driving autonomously, an ASR has to be present at the race control with the RES. Additionally, one single monitoring device (laptop, tablet, ...) may be brought (no complicated antenna construction or similar!).

D2.3 Ground Clearance

- D2.3.1 Sliding skirts or other aerodynamic devices that by design, fabrication or as a consequence of moving, contact the track surface are prohibited. Any violation may be penalized by a mechanical black flag.

D2 Driving Rules

D2.3.2 The ground clearance may be tested at any time.

D2.4 Practice Track

D2.4.1 A practice track for testing and tuning vehicles is available.

D2.4.2 [DV ONLY] A practice track for DV will be available (autonomous/manual).

D2.4.3 To use the practice track, vehicles must have passed all technical inspections.

D2.4.4 Practice or testing at any location other than the practice track is absolutely forbidden.

D2.5 [DV ONLY] Cones & Markings

D2.5.1 [DV ONLY] Details of the cones used and more detailed track layout figures can be found in the “DV event-specific technical specification” document .

D2.6 [DV ONLY] Start-up Procedure

D2.6.1 No additional equipment (e.g. laptop, jack-up device, pressure tank, etc.) is allowed to start up the vehicle at the staging/starting line.

D2.6.2 If the vehicle does not enter “AS Ready” state within 1 min after being staged, the team may be sent back to the preparation area by the officials.

D2.6.3 The vehicle may only be staged with the steering system in straight position.

D2.6.4 The vehicle may be pushed from the preparation area to the start line with activated GLVS

D2.6.5 The EBS may be armed already in the preparation area.

D2.7 [DV ONLY] Vehicle Break Downs and Usage of RES

D2.7.1 Stalling the engine or deactivating the tractive system for any reason during a dynamic event will result in DNF as the autonomous system is not allowed to restart the engine/reactivate the tractive system.

D2.7.2 If a vehicle comes to standstill for any reason, it may have up to 30 s to attempt to continue to drive. If the vehicle doesn’t restart within 30 s, it will be deactivated using the RES, deemed disabled and scored as DNF for the run.

D2.7.3 The ASR or the officials may stop the vehicle using the RES in any of the following cases:

- Its behavior seems to be uncontrolled (e.g. driving off-course).
- It is mechanically or electrically damaged.
- It is driving too slow.
- To ensure safe conditions on the track (e.g. persons or animals on the track). In this case the team will get a re-run.

D3 Weather Conditions

- D2.7.4 If a vehicle breaks down or is stopped by the use of the RES it will be removed from the course, will not be allowed to re-enter the course and scored DNF.
- D2.7.5 If a traceable signal loss of the RES appears and doubtless proof can be brought by the team that it is was not self-inflicted, a re-run may be granted.
- D2.7.6 At the direction of the officials, team members may be instructed to retrieve broken-down vehicles. This recovery may only be done under the control of the officials.

D2.8 [DV ONLY] Procedure After Completing a Dynamic Event

- D2.8.1 The vehicle must be collected by the ASR and an additional team member immediately after approval from the officials.

D3 WEATHER CONDITIONS

D3.1 Operating Conditions

- D3.1.1 The following track conditions are recognized:

- Dry
- Damp
- Wet

- D3.1.2 The operating condition are decided by the officials and may change at any time.

- D3.1.3 The current operating condition will be prominently displayed at the dynamic area.

D3.2 Tires Allowed

- D3.2.1 Teams must run the tires allowed for each operating condition:

Operating Condition	Tires allowed
Dry	Dry
Damp	Dry or Wet
Wet	Wet

- D3.2.2 When the operating condition is damp, teams may change between dry tires and wet tires:

- Any time during the acceleration, skidpad, and autocross events.
- Any time before taking the green flag to start endurance.

- D3.2.3 If an event had varied operating conditions, the minimum performance levels to score points may be adjusted if deemed appropriate by the officials.

- D3.2.4 Only one set of tires per type (dry/wet) may be used during all the dynamic events. The brake test, practice area and the static events are excluded from this regulation.

D4 Skidpad Event

D4 SKIDPAD EVENT

D4.1 Skidpad Track Layout

- D4.1.1 The skidpad course consists of two pairs of concentric circles in a figure of eight pattern.
- D4.1.2 The centers of these circles are 18.25 m apart. The inner circles are 15.25 m in diameter and the outer circles are 21.25 m in diameter.
- D4.1.3 16 cones are placed around the inside of each inner circle. 13 cones are positioned around the outside of each outer circle, in the pattern shown in the skidpad layout diagram.
- D4.1.4 Each circle is marked with a line, outside the inner circle and inside the outer circle.
- D4.1.5 The driving path is the 3 m wide path between the inner and outer circles. The vehicles enter and exit through gates on a 3 m wide path that is tangent to the circles where they meet.
- D4.1.6 The line between the centers of the circles defines the start/finish line. A lap is defined as traveling around one of the circles, starting and ending at the start/finish line.
- D4.1.7 Independent of the weather, the track conditions will be made artificially “wet” (not for DV).

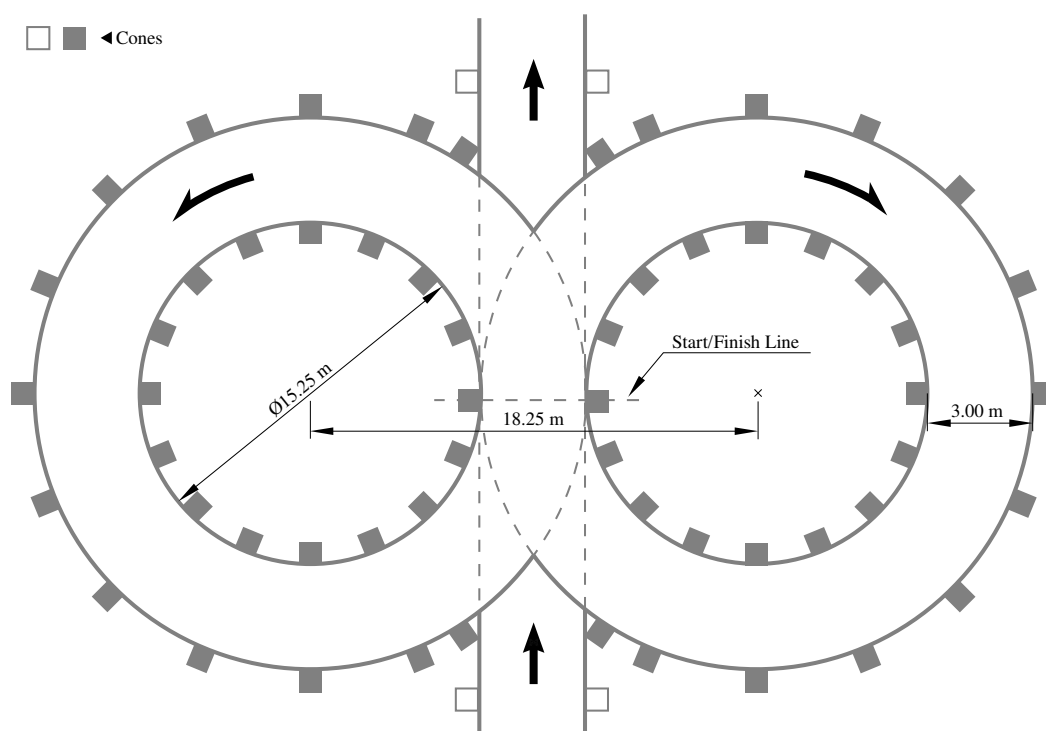

Figure 21: Skidpad Track Layout

D4.2 Skidpad Procedure

- D4.2.1 Each team has four runs, driven by two drivers with two runs each.
- D4.2.2 Each driver has the option to make a second run immediately after their first run.

D4 Skidpad Event

- D4.2.3 The starting order is based on the time the team arrives at the skidpad event. Teams on their first run will receive priority.
- D4.2.4 Starting - A green flag is used to indicate that the driver may start.
- D4.2.5 The vehicle will enter perpendicular to the figure of eight and will take one full lap on the right circle to establish the turn. The next lap will be on the right circle and will be timed. Immediately following the second lap, the vehicle will enter the left circle for the third lap. The fourth lap will be on the left circle and will be timed. Immediately upon finishing the fourth lap, the vehicle will exit the track perpendicular to the figure of eight and moving in the same direction as entered.

D4.3 [DV ONLY] Skidpad Procedure

- D4.3.1 Each team has at least two runs. The final number of runs will be published before the start of the event.
- D4.3.2 Starting order is based upon time of arrival. Teams on their first run will receive priority.
- D4.3.3 Staging - The foremost part of the vehicle is staged 15 m in front of the timekeeping line.
- D4.3.4 Starting - A go-signal from RES is used to indicate the approval to begin.
- D4.3.5 The vehicle will enter perpendicular to the figure eight and will take one full lap on the right circle to establish the turn. The next lap will be on the right circle and will be timed. Immediately following the second lap, the vehicle will enter the left circle for the third lap. The fourth lap will be on the left circle and will be timed. Immediately upon finishing the fourth lap, the vehicle will exit the track.
- D4.3.6 The vehicle will exit at the intersection moving in the same direction as entered and must come to a full stop within 25 m behind the timekeeping line, inside the marked exit lane and enter the finish-state described in DV 2.3.

D4.4 Skidpad Scoring

- D4.4.1 The run time is the average time of the timed left and the timed right circle plus penalties which are added after the averaging.
- D4.4.2 3.5 points are awarded to every team that finishes at least one run without DNF.
- D4.4.3 If a team's run time including penalties is below T_{\max} , additional points based on the following formula are given:

$$SKIDPADSCORE = 71.5 \left(\frac{\left(\frac{T_{\max}}{T_{\text{team}}} \right)^2 - 1}{0.5625} \right)$$

T_{team} is the team's best run time including penalties.

T_{\max} is 1.25 times the time of the fastest vehicle including penalties.

D5 Acceleration Event

- D4.4.4 [DV ONLY] If a team's run time including penalties is below T_{\max} , additional points based on the following formula are given:

$$SKIDPADSCORE = 71.5 \left(\frac{\left(\frac{T_{\max}}{T_{\text{team}}} \right)^2 - 1}{1.25} \right)$$

T_{team} is the team's best run time including penalties.

T_{\max} is 1.5 times the time of the fastest vehicle including penalties.

D5 ACCELERATION EVENT

D5.1 Acceleration Track Layout

- D5.1.1 The acceleration course is a straight line with a length of 75 m from starting line to finish line. The course is at least 5 m wide. Cones are placed along the course at intervals of about 5 m. Cone locations are not marked on the pavement.
- D5.1.2 [DV ONLY] The course is 3 m wide.

D5.2 Acceleration Procedure

- D5.2.1 Each team has four runs, driven by two drivers with two runs each.
- D5.2.2 Each driver has the option to make a second run immediately after their first run.
- D5.2.3 Staging - The foremost part of the vehicle is staged 0.30 m behind the starting line. Vehicles will accelerate from a standing start.
- D5.2.4 Starting - A green flag is used to indicate that the driver may start. Timing starts after the vehicle crosses the starting line and stops after it crosses the finish line.
- D5.2.5 The starting order is based on the time the team arrives at the acceleration event. Teams on their first run will receive priority.

D5.3 [DV ONLY] Acceleration Procedure

- D5.3.1 Each team has at least two runs. The final number of runs will be published before the start of the event.
- D5.3.2 Staging - The foremost part of the vehicle is staged at 0.30 m behind the starting line. Vehicles will accelerate from a standing start.
- D5.3.3 Starting - A go-signal from RES is used to indicate the approval to begin, timing starts only after the vehicle crosses the starting line and stops after it crosses the finish line.
- D5.3.4 After the finish line, the vehicle must come to a full stop within 100 m inside the marked exit lane and enter the finish-state described in DV 2.3.
- D5.3.5 Starting order is based upon time of arrival. Teams on their first run will receive priority.

D6 Autocross Event

D5.4 Acceleration Scoring

D5.4.1 3.5 points are awarded to every team that finishes at least one run without a DNF.

D5.4.2 If a team's best time including penalties is below T_{\max} , additional points based on the following formula are given:

$$ACCELERATIONSCORE = 71.5 \left(\frac{\frac{T_{\max}}{T_{\text{team}}} - 1}{0.5} \right)$$

T_{team} is the team's best time including penalties.

T_{\max} is 1.5 times the time of the fastest vehicle including penalties.

D5.4.3 [DV ONLY] If a team's best time including penalties is below T_{\max} , additional points based on the following formula are given:

$$ACCELERATIONSCORE = 71.5 \left(\frac{T_{\max}}{T_{\text{team}}} - 1 \right)$$

T_{team} is the team's best time including penalties.

T_{\max} is 2 times the time of the fastest vehicle including penalties.

D6 AUTOCROSS EVENT

D6.1 Autocross Track Layout

D6.1.1 The autocross track layout is a handling course built to the following guidelines:

- Straights: No longer than 80 m
- Constant Turns: up to 50 m diameter
- Hairpin Turns: Minimum of 9 m outside diameter (of the turn)
- Slaloms: Cones in a straight line with 7.5 m to 12 m spacing
- Miscellaneous: Chicanes, multiple turns, decreasing radius turns, etc. The minimum track width is 3 m.

D6.1.2 The length of the autocross track is less than 1.5 km.

D6.2 Autocross Procedure

D6.2.1 Each team has up to four runs, driven by two drivers with two runs each.

D6.2.2 Each driver has the option to make a second run immediately after their first run.

D6.2.3 Staging - The vehicle is staged at a staging line prior to the starting line.

D6.2.4 Starting - A green flag is used to indicate that the driver may start. Timing starts only after the vehicle crosses the starting line and stops after it crosses the finish line.

D6.2.5 The starting order is based on the time the team arrives at the autocross event. Teams on their first run will receive priority.

D7 Endurance and Efficiency Event

D6.3 Autocross Scoring

D6.3.1 4.5 points are awarded to every team that finishes at least one run without DNF.

D6.3.2 If a team's corrected elapsed time is below T_{\max} , points based on the following formula are given:

$$AUTOCROSSSCORE = 95.5 \left(\frac{\frac{T_{\max}}{T_{\text{team}}} - 1}{0.25} \right)$$

T_{team} is the team's best time including penalties.

T_{\max} is 1.25 times the time of the fastest vehicle including penalties.

D7 ENDURANCE AND EFFICIENCY EVENT

D7.1 Endurance Track Layout

D7.1.1 The endurance track layout is a closed lap circuit built to the following guidelines:

- Straights: No longer than 80 m
- Constant Turns: up to 50 m diameter
- Hairpin Turns: Minimum of 9 m outside diameter (of the turn)
- Slaloms: Cones in a straight line with 9 m to 15 m spacing
- Miscellaneous: Chicanes, multiple turns, decreasing radius turns, etc.
- The minimum track width is 3 m

D7.1.2 The length of one lap of the endurance track is approximately 1 km.

D7.1.3 The length of the complete endurance is approximately 22 km.

D7.2 Endurance Procedure

D7.2.1 Before entering the event, each CV's fuel tank must be filled to the fuel level line (see CV2.6.3, "Fuel Level Line") at the fueling station. During fueling, once filled to the scribe line, no shaking or tilting of the tank, the fuel system or the entire vehicle is allowed.

D7.2.2 There is only one run for the endurance event.

D7.2.3 A driver change must be made during a three minute period at the midpoint of the run.

D7.2.4 Staging - The vehicle is staged at a staging line prior to the starting line. The timer starts only after the vehicle crosses the start line.

D7.2.5 Starting - A green flag is used to indicate that the driver may start. Timing starts only after the vehicle crosses the starting line.

D7.2.6 The first driver will drive for 11 km and will then be signaled into the driver change area.

D7.2.7 After the driver change specified in D7.4, the second driver will drive for an additional 11 km and will be signaled to exit the track after crossing the finish line.

D7.2.8 After leaving the track, the vehicle must be powered down.

D7 Endurance and Efficiency Event

- D7.2.9 For CV, the second driver will proceed directly to the fueling station. The tank will be filled to the refill mark and the amount of fuel will be recorded.
- D7.2.10 For EVs, the second driver will proceed directly to the data logger download station, where the data will be downloaded.
- D7.2.11 The starting order is defined by the officials so that vehicles of similar speed potential are on track together, to reduce the need for overtaking.

D7.3 Passing

- D7.3.1 During the endurance event, overtaking is only permissible in the designated passing zones and under the control of the track marshals.
- D7.3.2 Passing zones have two parallel lanes, a slow lane only used by the vehicles that are being overtaken and a fast lane for the vehicles that are overtaking.
- D7.3.3 Passing zones may be situated on either the left or right of the fast lane.
- D7.3.4 The passing zone procedure will be as follows:
- A slower leading vehicle will be shown the blue flag and must drive into the slow lane and decelerate.
 - The following faster vehicle will continue in the fast lane to pass the slow vehicle.
 - The vehicle that has been overtaken may re-enter the track when the track marshal who is in charge of that passing zone is showing the green flag.
- D7.3.5 The passing rules do not apply to vehicles that are stopped on track or vehicles that have spun out and are not moving. When passing a stationary vehicle, it is critical to slow down, drive cautiously and to follow the instructions from the track marshals.

D7.4 Endurance Driver Change Procedure

- D7.4.1 Only three team members including the driver may enter the driver change area. They may only bring the tools required to adjust the vehicle to accommodate the second driver and/or change tires.
- D7.4.2 For electric vehicles one of the team members must be an ESO.
- D7.4.3 During the driver change, the team may:
- perform changes to accommodate the second driver
 - operate the master switch(es)
 - change tires as per D7.5.
- No other work may be performed during the driver change.
- D7.4.4 Each team is given three minutes to change their driver.
- D7.4.5 The driver change time will start once the vehicle is stopped in the driver change area and the first driver has turned off the engine for CV or turned off the tractive system for EVs.

D7 Endurance and Efficiency Event

- D7.4.6 [EV ONLY] The TSMS must be switched off by the ESO and the TSAL must have changed to green color, before anyone is allowed to touch the vehicle or to climb out the vehicle.
- D7.4.7 The first driver will climb out the vehicle and any necessary adjustments will be made to the vehicle to fit the second driver (seat cushions, head restraint, pedal position, etc.). The second driver will then be secured in the vehicle.
- D7.4.8 When the second driver is fully secured in the vehicle, the vehicle has restarted and is ready-to-drive again, the driver change time is stopped.
- D7.4.9 If the driver change takes longer than three minutes, the extra time is included in the final time.

D7.5 Endurance Event Tire Changes

- D7.5.1 All tire changes after a vehicle has received the green flag to start the endurance event must take place in the driver change area.
- D7.5.2 If the operating condition changes to wet during endurance, the track will be red flagged and all vehicles brought into the driver change area.
- D7.5.3 If a team wants to change tires, the officials must be informed beforehand.
- D7.5.4 In some cases, tire changes can be carried out directly after the driver change, for others the team must make an extra stop.
- D7.5.5 The allowed tire changes and associated conditions are given in the following tables.

Existing Operating Condition	Currently running on	Condition changes to Dry	Condition changes to Damp	Condition changes to Wet
Dry	Dry Tires	–	A	B
Damp	Dry Tires	–	A	B
Damp	Wet Tires	C	C	–
Wet	Wet Tires	C	C	–

	Requirement	Allowed at Driver Change?	Time Allowed
A	may change from dry to wet	yes	Note 1
B	must change from dry to wet	yes	Note 1
C	may change from wet to dry	no	Note 2

Note 1: Any time in excess of ten minutes without driver change, or thirteen minutes with driver change, is added to the team's total time for endurance.

Note 2: The time used to change to dry tires is added to the team's total time for endurance.

- D7.5.6 Teams that have incurred a puncture during the endurance event due to external factors (e.g. debris on track) may change the tire with no time penalty.
- D7.5.7 The wheel will be inspected by the officials. If the deflation was not caused by external factors, the vehicle will be scored DNF.
- D7.5.8 Deflation caused by running off course or impacting barriers or other objects due to driver error will not be regarded as external factors.

D7 Endurance and Efficiency Event

D7.6 Endurance Specific Regulations

- D7.6.1 Teams are prohibited from working on or fueling their vehicles during the run.
- D7.6.2 Wheel-to-wheel racing is prohibited.
- D7.6.3 Passing another vehicle must be completed as per D7.3.
- D7.6.4 If a vehicle stalls out on the track, it is allowed one lap by the vehicle that is following it (approximately one minute) to restart.
- D7.6.5 If a vehicle has a restart problem at the driver change or after a red flag, it is allowed two minutes to restart the engine or to enable the tractive system. The two minutes start from the time the driver first tries to restart the engine or to enable the tractive system. The time is counted towards the endurance time.
- D7.6.6 If restarts are not accomplished within the above times, the vehicle is scored as DNF for the run.
- D7.6.7 If a vehicle breaks down it will be removed from the course and will not be allowed to re-enter the course.
- D7.6.8 Team members may be instructed by the officials to retrieve broken down vehicles. This recovery may only be carried out under the control of the officials.

D7.7 Endurance Scoring

- D7.7.1 Each lap of the endurance event is individually timed. The corrected elapsed time is determined by subtracting the extra-long lap for the driver change from the total time and adding any penalty times.
- D7.7.2 The post event technical inspection (see IN 12) must be passed to score points in the endurance event.
- D7.7.3 25 points are awarded to every team that finishes endurance without DNF.
- D7.7.4 If a team's corrected elapsed time is below T_{\max} , additional points based on the following formula are given:

$$ENDURANCESCORE = 300 \left(\frac{\frac{T_{\max}}{T_{\text{team}}} - 1}{0.333} \right)$$

T_{team} is the team's corrected elapsed time.

T_{\max} is 1.333 times of the corrected elapsed time of the fastest vehicle.

D7.8 [CV ONLY] Efficiency Scoring

- D7.8.1 Energy efficiency is measured during the endurance event.
- D7.8.2 Only vehicles which score points in the endurance event will receive points for efficiency.
- D7.8.3 Teams whose fuel volume used during the endurance event exceeds 26l/100km receive zero points for fuel efficiency.

D7 Endurance and Efficiency Event

D7.8.4 Teams whose corrected elapsed endurance time exceeds T_{\max} as defined in D7.7.4 receive zero points for efficiency.

D7.8.5 Fuel pumps will be turned on and fuel valves will be opened to ensure complete refueling.

D7.8.6 If a team finishes the endurance event, efficiency points based on the following formula are given:

$$EFFICIENCYSCORE = 100 \left(\frac{\frac{E_{\min}}{E_{\text{team}}} - 1}{\frac{E_{\min}}{E_{\max}} - 1} \right)$$

E_{team} is the team's efficiency factor.

E_{\max} is the highest efficiency factor of all teams who are able to score points in efficiency.

E_{\min} is the lowest efficiency factor of all teams who are able to score points in efficiency.

D7.8.7 The efficiency factor is calculated based on the following formula:

$$EFFICIENCYFACTOR = \frac{T_{\min} \cdot V_{\min}}{T_{\text{team}} \cdot V_{\text{team}}}$$

T_{team} is the team's corrected elapsed time.

T_{\min} is the fastest corrected elapsed time of all teams who are able to score points in efficiency.

V_{team} is the team's corrected used fuel volume.

V_{\min} is the lowest corrected used fuel volume of all teams who are able to score points in efficiency.

D7.8.8 The measured fuel volume of vehicles using E 85 fuel is divided by 1.4 to be comparable to the vehicles using 98 RON.

D7.9 [EV ONLY] Efficiency Scoring

D7.9.1 Energy efficiency is measured during the endurance event.

D7.9.2 The endurance energy is calculated as the time integrated value of the measured voltage multiplied by the measured current logged by the energy meter. Regenerated energy is multiplied by 0.9 and subtracted from the used energy.

D7.9.3 Only vehicles which score points in the endurance event will receive points for efficiency.

D7.9.4 Teams whose corrected elapsed endurance time exceeds T_{\max} as defined in D7.7.4 receive zero points for efficiency.

D7.9.5 If a team finishes the endurance event, efficiency points based on the following formula are given:

$$EFFICIENCYSCORE = 100 \left(\frac{\frac{0.1}{E_{\text{team}}} - 1}{\frac{0.1}{E_{\max}} - 1} \right)$$

E_{team} is the team's efficiency factor.

E_{\max} is the highest efficiency factor of all teams who are able to score points in efficiency.

D8 [DV ONLY] Trackdrive and Efficiency Event

D7.9.6 The efficiency factor is calculated based on the following formula:

$$EFFICIENCYFACTOR = \frac{T_{\min} \cdot EN_{\min}^2}{T_{\text{team}} \cdot EN_{\text{team}}^2}$$

T_{team} is the team's corrected elapsed time.

T_{\min} is the fastest corrected elapsed time of all teams who are able to score points in efficiency.

EN_{team} is the team's corrected used energy.

EN_{\min} is the lowest corrected used energy of all teams who are able to score points in efficiency.

D8 [DV ONLY] TRACKDRIVE AND EFFICIENCY EVENT

D8.1 Trackdrive Tracklayout

D8.1.1 The trackdrive layout is a closed loop circuit built to the following guidelines:

- Straights: No longer than 80 m
- Constant Turns: up to 50 m diameter
- Hairpin Turns: Minimum of 9 m outside diameter (of the turn)
- Miscellaneous: Chicanes, multiple turns, decreasing radius turns, etc.
- The minimum track width is 3 m

D8.1.2 The length of one lap is approximately 200 m to 500 m.

D8.2 Trackdrive Procedure

D8.2.1 Starting order is defined by the officials, based on acceleration and skidpad results.

D8.2.2 Before entering the event, each DV, with a fuel tank (CV), must be filled to the fuel level line (see CV 2.6.3, "Fuel Level Line") at the fueling station. During fueling, once filled to the scribe line, no shaking or tilting of the tank, the fuel system or the entire vehicle is allowed.

D8.2.3 There will be at least one run consisting of ten laps. The number of runs and the starting order procedure will be announced before the start of the event.

D8.2.4 Staging - The vehicle is staged such that the front wheels are 6 m in front of the starting line on the track.

D8.2.5 Starting - A go-signal from RES is used to indicate the approval to begin. Timing starts after the vehicle crosses the starting line.

D8.2.6 After ten laps the vehicle must come to a full stop within 30 m behind the finish line on the track and enter the finish-state described in DV 2.4.

D8.2.7 There will be no last lap signal i.e. the vehicle should count laps itself.

D8.2.8 The team must proceed directly to the fueling station (DV with internal combustion engine only) and to the data logger download station after finishing trackdrive.

D9 Dynamic Events Penalties

D8.3 Trackdrive Course Walk

D8.3.1 There will be a course walk prior to the trackdrive. During the course walk no equipment (e.g. antennas, sensors, cameras, etc) other than analog measurement devices (i.e. measurement wheel or measurement tape) is allowed.

D8.4 Trackdrive Scoring

D8.4.1 Each lap of the trackdrive event is individually timed. The corrected elapsed time is determined by adding any penalty times.

D8.4.2 If a team's corrected elapsed time is below T_{\max} and the run was not DNF, points based on the following formula are given:

$$TRACKDRIVESCORE = 150 \left(\frac{\frac{T_{\max}}{T_{\text{team}}} - 1}{0.5} \right)$$

T_{team} is the team's corrected elapsed time.

T_{\max} is 1.5 times of the corrected elapsed time of the fastest vehicle.

D8.4.3 An additional ten points are awarded for every completed lap, independent of the corrected elapsed time. This is also applied for teams that do not finish the trackdrive i.e. get a DNF.

D8.5 Efficiency Scoring

D8.5.1 Energy efficiency is measured during the trackdrive event.

D8.5.2 Only vehicles which complete the trackdrive event will receive points for efficiency.

D8.5.3 [EV ONLY] Rules D7.9.1 to D7.9.4 are applied.

D8.5.4 [CV ONLY] Rules D7.8.3 to D7.8.5 and D7.8.8 are applied.

D8.5.5 [CV ONLY] The trackdrive energy is calculated based on following formula:

$$E_{\text{team}} = V_{\text{team}} \cdot 3.55 \text{ kWh/l}$$

V_{team} is the team's corrected used fuel volume.

D8.5.6 The team's efficiency is calculated based on D7.9.5 and D7.9.6.

D9 DYNAMIC EVENTS PENALTIES

D9.1 General Penalties

D9.1.1 Penalties will not be assessed for accident avoidance or other reasons deemed sufficient by the officials.

D9 Dynamic Events Penalties

- D9.1.2 A cone is Down or Out (DOO) if the cone has been knocked over or the entire base of the cone lies outside the box marked around the cone in its undisturbed position.
- D9.1.3 [DV ONLY] Cones that are DOO are not replaced/reset during the run. There will be no re-run due to cones in the driving path or disorientation due to missing cones.
- D9.1.4 The DOO penalty (see D9.1.7) is added for each DOO including entry and exit gate cones before the start and after the finish line, that occur on that particular run.
- D9.1.5 Off-course (OC)
- An OC occurs when the vehicle has all four wheels outside the course boundary as indicated by edge marking.
 - Missing one or more gates of a given slalom at autocross or endurance is counted as one OC per occurrence.
 - When an OC occurs, the driver must re-enter the track at the next possible point.
 - When re-entering the driver needs to wait for a gap and follow the instructions of the track marshals.
- D9.1.6 [DV ONLY] An Unsafe Stop (USS) is defined as not stopping within the specified area and/or not entering the finish-state described in DV 2.4.
- D9.1.7
- | | Acceleration | Skidpad | Autocross | Endurance | Trackdrive |
|-----|--------------|---------|-----------|-----------|------------|
| DOO | 2 s | 0.2 s | 2 s | 2 s | 2 s |
| OC | DNF | DNF | 10 s | 10 s | DNF |
| USS | DNF | DNF | n/a | n/a | −50 points |
- D9.1.8 DNF equals zero points for that run.
- D9.1.9 If a team Did Not Attempt (DNA) an event the score is zero points.
- D9.1.10 Each run with an incorrect number of laps at skidpad is classified as DNF.
- D9.1.11 Failure to obey a flag: one minute time penalty.
- D9.1.12 Reckless or aggressive driving or “Over Driving”: black flag (see D 2.1.3)
- D9.1.13 Vehicle to vehicle contact: Two minutes up to disqualification depending on the nature of the incident.
- D9.1.14 If a vehicle stalls and cannot restart without external assistance, the vehicle is DNF for that run.

D9.2 Endurance Penalties

- D9.2.1 Out of order running: Teams that are not ready-to-race when their turn arrives for endurance are penalized two minutes and may then run at the discretion of the officials.
- D9.2.2 Mechanical Problem: The time taken for mechanical inspection under a “mechanical black flag” (see D 2.1.4) is considered officials’ time and is not included in the team’s total time. If the inspection reveals a mechanical integrity problem the vehicle is scored DNF.
- D9.2.3 If it is impossible to impose a penalty by a stop under a black flag, e.g. not enough laps left, the officials may add an appropriate time penalty to the team’s elapsed time.

D9 Dynamic Events Penalties

D9.2.4 A team may receive a DNF if their vehicle is too slow or being driven without proper control.

D9.2.5 Any violation to the procedure of driver change (D7.4.3) will lead to a time penalty of up to two minutes.

D9.3 [CV ONLY] Efficiency Penalties

D9.3.1 Should the fuel level change after refueling due to effects such as described in CV2.7.1, then the difference in fuel level will be measured and twice the amount will be added to the official fuel consumption figure.

D9.4 [EV ONLY] Power and Voltage Violation Penalties

D9.4.1 A violation is defined as using more than the maximum power, see EV2.2, or exceeding the specified voltage, see EV5.1.1, after a moving average over 500 ms is applied to the respective data logger signal, see EV5.6.

D9.4.2 Each violation, is DNF for the fastest run of the event. If a violation occurred during two runs, the two fastest runs will be DNF etc. .

D9.4.3 The respective data and the resulting decision of violations may be made public.

D9.4.4 Non-availability of data logger data due to the team's fault will be treated as a violation.